

SLUDGE-PUMP-SYSTEMS MUCK PUMPS

overview



CONTENTS

SLUDGE PUMPS

- 06 | 07 Fields of application KSP
- 08 | 09 KSP / TAP / EHS / SD -Abbreviations explained
- 10 | 11 Poppelt Valve System / Rock Valve System
- 12 | 13 KSP 5 HD / KSP 10 HDV
- 14 | 15 KSP 12 HD / KSP 17 HDV
- 16 | 17 KSP 25 HDR / KSP 40 HD
- 18 | 19 KSP 45 HD / KSP 50 HDV
- 20 | 21 KSP 65 HDR / KSP 80 HDV
- 22 | 23 KSP 110 HD / 140 HDV
- 24 | 25 KSP 220 HDR / KSP 315 XL

MUCK PUMPS

- 26 | 27 TAP 30 R / TAP 50 R / TAP 90 R / TAP 110 R

HYDRAULIC POWER PACKS

- 28 | 29 EHS 100 - EHS 5000

ELECTRICAL CONTROL SYSTEMS

- 30 | 31 Control systems

FEEDING SYSTEMS

- 32 | 33 Double screw feeders

ACCESSORIES

- 34 | 35 Wide Range of Accessories
- 36 | 37 References
- 38 | 39 For Notes

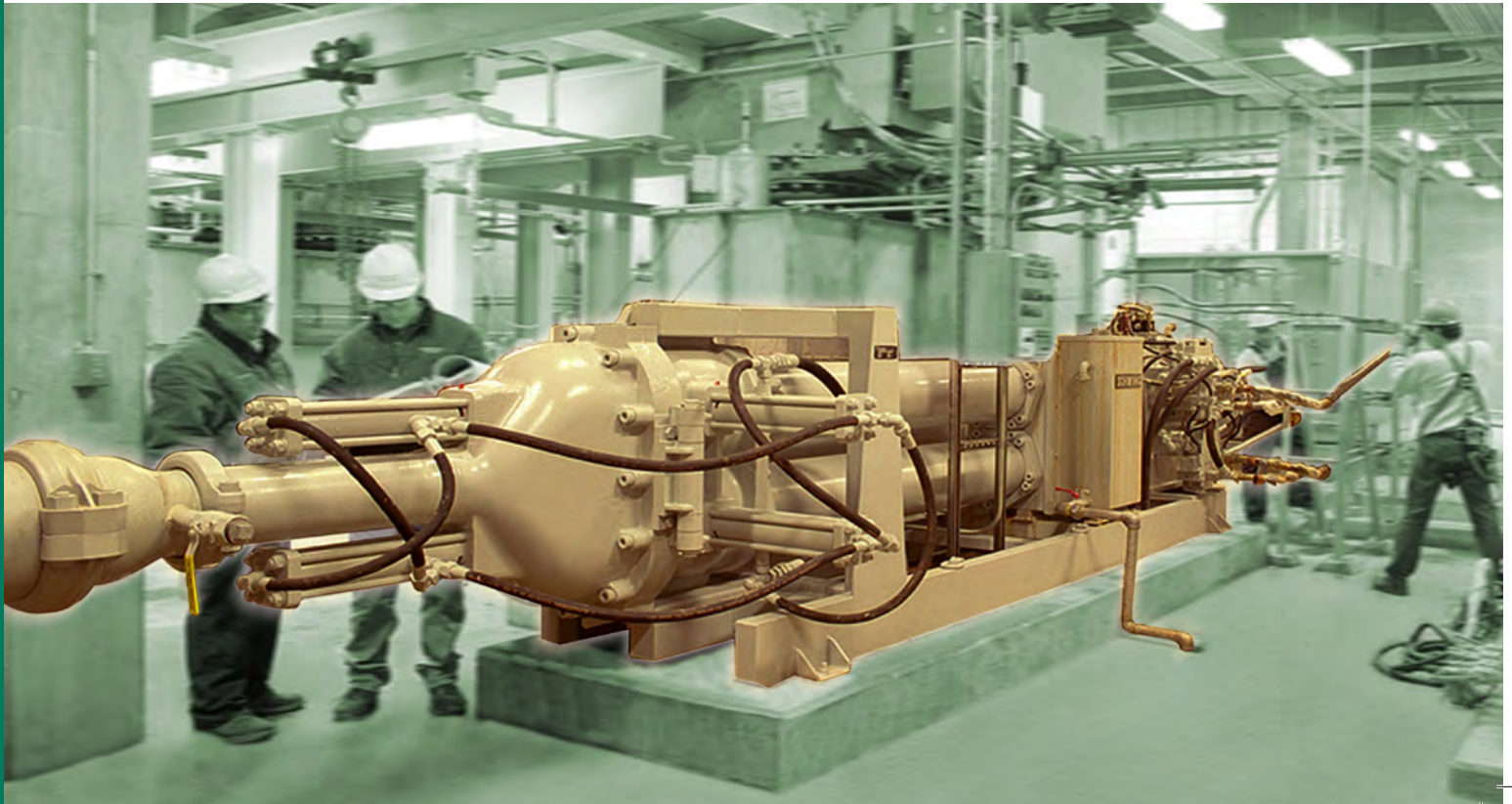

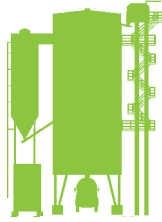

CONCRETE BATCHING PLANTS



TRUCK MIXERS



TRUCK MIXER CONCRETE PUMPS



TRUCK-MOUNTED CONCRETE PUMPS



STATIONARY CONCRETE PUMPS



SEPARATE PLACING BOOMS



CONCRETE RECYCLERS



SLUDGE PUMPS

SCHWING SLUDGE PUMPS IN WORLDWIDE OPERATION.

SCHWING is one of the leading manufacturers of sludge pumps and provides turnkey solutions for the transport and storage of sludges as well as materials with a high solids content. A detailed customer oriented project planning and an effective design go hand in hand with a thorough consultation that rounds off the full scope of the competent SCHWING Team.

For the optimum results SCHWING relies on the in-house production of all major components such as piston pumps, electric control systems, silos, continuous dosing and mixing devices, double screw conveyors, pipelines and accessories.

You can rely on SCHWING to support its customer long after delivery and start-up. Our after sales care includes Training and Service for all your project needs.

- High performance design
- Reliable and safe
- Low owning and operating costs
- Low maintenance costs

KSP - FIELDS OF APPLICATION

WASTE WATER TREATMENT PLANTS (WWTP)

- Sewage sludge mechanically dewatered and with foreign particles

WASTE RECYCLING

- Waste sludge
- Oil sludge
- Salt mud
- Radioactive waste
- Et al.

CONSTRUCTION INDUSTRY

- Bentonite
- Clay mud
- Mortar
- Tailings
- Et al.

MINING | REFINERIES | POWER PLANTS

- Red mud
- Gold slime
- Iron sludge
- Zinc sludge
- Metallic oxide sludge
- Fly ash
- Et al.

CHEMISTRY AND INDUSTRY

- Organic and inorganic materials
- Stabilized chemical waste
- Lime slurry
- Food-processing by-products
- Paint sludges

FORAGE INDUSTRY

- Cattle fodder
- Fish waste
- Animal carcass by-products
- Animal waste

WATER SLUDGE REMOVAL

- Dredged material
- Water sludge
- Silt

PAPER INDUSTRY

- Paper pulp

CLEANING

- Contaminated soil

RESIDUES

- Waste water sludge

SUGAR INDUSTRY

- Carbonation sludge

SLUDGE PUMPS

EXAMPLE

- **KSP 25 HDV (k)**

KSP = Piston Sludge Pump
 25 = Volume of material cylinder in litres
 HD = High pressure version
 k = Differential cylinder on piston side

- **KSP 12-2D (s)**

12 = Volume of material cylinder in litres
 w/o marking = horizontal pump configuration
 (material cylinders side by side)
 2D = Dual outlet (one outlet per cylinder)
 s = Differential cylinder on rod side

- **KSP 45 R**

45 = Volume of material cylinder in litres
 R = Rock Valve

- **KSP 80 V**

80 = Volume of material cylinder in litres
 V = Vertical pump configuration
 (material cylinders over / under)

MUCK PUMPS

EXAMPLE

- **TAP 90 R**

TAP = Tunnel Muck Pump
 90 = Volume of material cylinder in litres
 R = Rock Valve

HYDRAULIC POWER PACKS

EXAMPLE

- **EHS 190-22 kW-LK**

EHS = Electro-Hydraulic System
 190 = Tank capacity in litres
 22 kW = Power of electric motor 22kW
 LK = Air cooler / alternatively
 WK = Water cooler

DOUBLE SCREW FEEDERS

EXAMPLE

- **SD 350-1000-H**

SD = Double Screw Feeder
 350 = Diameter of screw spirals in mm
 1000 = Inlet opening in mm
 H = Hydraulic drive
 E = Electric drive

KSP with dual outlet

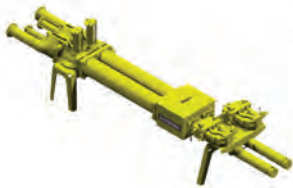

KSP with XL poppets and vertical configuration

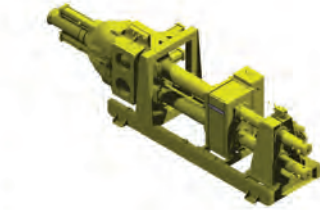

KSP with horizontal configuration



KSP with Rock valve system

AVAILABLE PUMP CONFIGURATIONS

Both

- horizontal "H" (material cylinders side by side)

and

- vertical "V" (material cylinders over / under)

with

a) Poppet Valve System

- small (KSP 5 - 40)
- large (KSP 12 - 220)
- XL (KSP 45 - 315)

Ø diameter suction valves / pressure valves

DN 125 mm / DN 100 mm
 DN 210 mm / DN 150 mm
 DN 280 mm / DN 250 mm

b) Rock Valve System

- KSP 5 - 40
- KSP 12 - 220
- KSP 12 - 220

Model

Rock small (RK / 80 bar)
 Rock large/medium (RML-TAP / 100 bar)
 Rock large/medium (RMHP / 160 bar)

All pump models with small and large poppet valves are also available with dual outlet (-2D).

POPPET VALVE SYSTEM ROCK VALVE UNIT

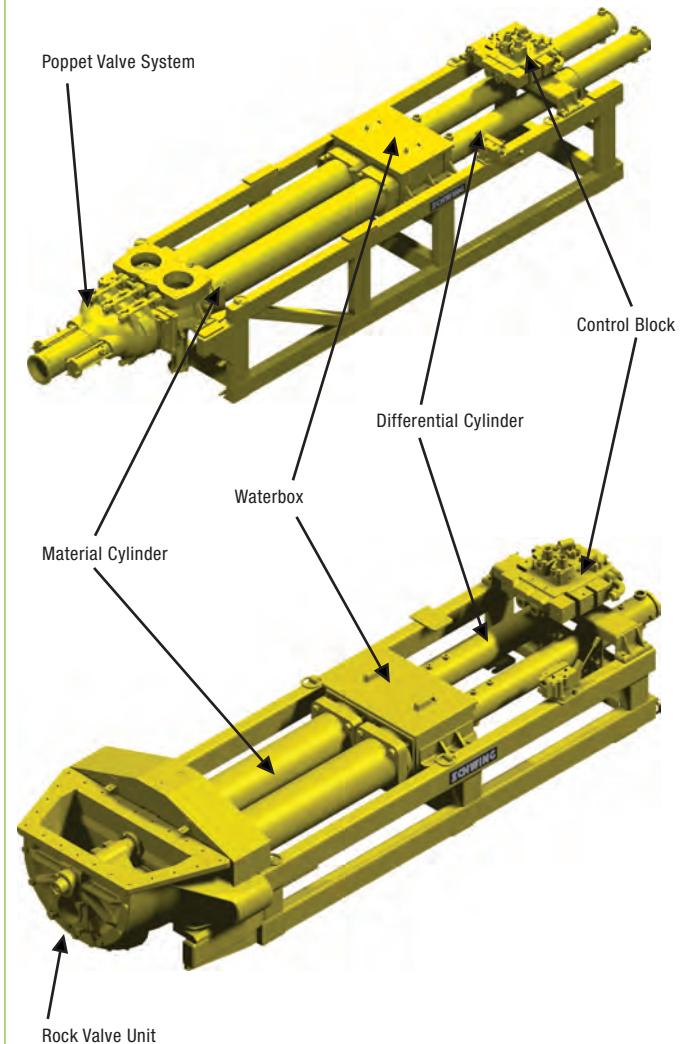

**TECHNICAL DATA**

Min. and max. output*	m ³ /hr	0,4 - 3,0
Max. design pressure	bar	130
Length	mm	2800
Width	mm	700
Height	mm	850
Weight approx.	kg	900
Diam. of material cylinder	mm	115
Diam. of differential cylinder	mm	125
Stroke length	mm	500

* Max. output depending on consistency of material to be pumped.

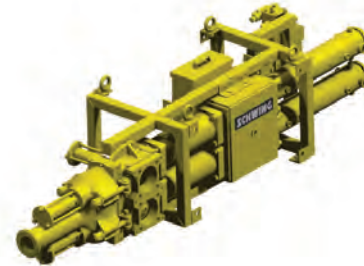
**TECHNICAL DATA**

Min. and max. output*	m ³ /hr	0,5 - 5,0
Max. design pressure	bar	130
Length	mm	2950
Width	mm	700
Height	mm	850
Weight approx.	kg	950
Diam. of material cylinder	mm	150
Diam. of differential cylinder	mm	125
Stroke length	mm	500

* Max. output depending on consistency of material to be pumped.

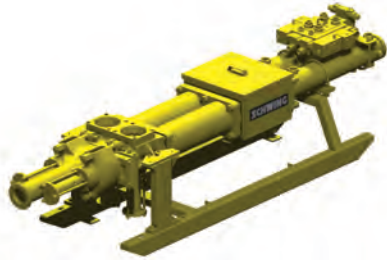
**TECHNICAL DATA**

Min. and max. output*	m ³ /hr	1,0 - 7,0
Max. design pressure	bar	120
Length	mm	3150
Width	mm	700
Height	mm	850
Weight approx.	kg	980
Diam. of material cylinder	mm	180
Diam. of differential cylinder	mm	125
Stroke length	mm	500

* Max. output depending on consistency of material to be pumped.

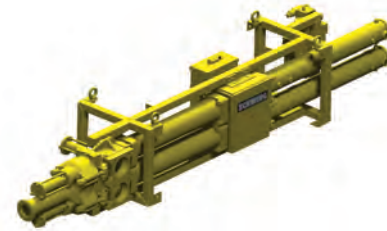
**TECHNICAL DATA**

Min. and max. output*	m ³ /hr	1,5 - 10,0
Max. design pressure	bar	130
Length	mm	3960
Width	mm	700
Height	mm	850
Weight approx.	kg	1.000
Diam. of material cylinder	mm	150
Diam. of differential cylinder	mm	125
Stroke length	mm	1000

* Max. output depending on consistency of material to be pumped.

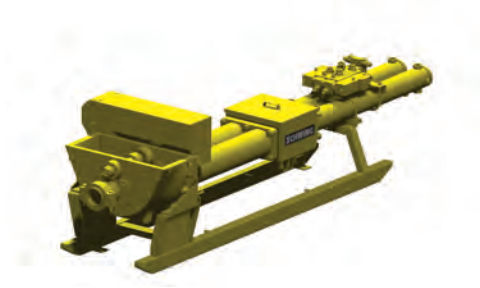
**TECHNICAL DATA**

Min. and max. output*	m ³ /hr	2,0 - 15,0
Max. design pressure	bar	80
Length	mm	3650
Width	mm	1050
Height	mm	1100
Weight approx.	kg	1.300
Diam. of material cylinder	mm	180
Diam. of differential cylinder	mm	125
Stroke length	mm	1000

* Max. output depending on consistency of material to be pumped.

**TECHNICAL DATA**

Min. and max. output*	m ³ /hr	1,0 - 20,0
Max. design pressure	bar	130
Length	mm	5200
Width	mm	700
Height	mm	850
Weight approx.	kg	1.600
Diam. of material cylinder	mm	180
Diam. of differential cylinder	mm	150
Stroke length	mm	1600

* Max. output depending on consistency of material to be pumped.

**TECHNICAL DATA**

Min. and max. output*	m ³ /hr	2,5 - 30,0
Max. design pressure	bar	106
Length	mm	4300
Width	mm	1000
Height	mm	1000
Weight approx.	kg	2.250
Diam. of material cylinder	mm	230
Diam. of differential cylinder	mm	150
Stroke length	mm	1000

* Max. output depending on consistency of material to be pumped.

**TECHNICAL DATA**

Min. and max. output*	m ³ /hr	3,0 - 40,0
Max. design pressure	bar	130
Length	mm	6250
Width	mm	1500
Height	mm	1450
Weight approx.	kg	4.900
Diam. of material cylinder	mm	200
Diam. of differential cylinder	mm	150
Stroke length	mm	1600

* Max. output depending on consistency of material to be pumped.

**TECHNICAL DATA**

Min. and max. output*	m ³ /hr	4,0 - 60,0
Max. design pressure	bar	100
Length	mm	5800
Width	mm	1350
Height	mm	1100
Weight approx.	kg	2.850
Diam. of material cylinder	mm	230
Diam. of differential cylinder	mm	150
Stroke length	mm	1600

* Max. output depending on consistency of material to be pumped.

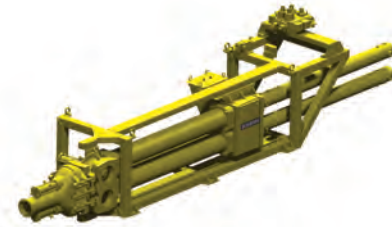
**TECHNICAL DATA**

Min. and max. output*	m ³ /hr	5,0 - 70,0
Max. design pressure	bar	106
Length	mm	7000
Width	mm	1500
Height	mm	1450
Weight approx.	kg	5.200
Diam. of material cylinder	mm	230
Diam. of differential cylinder	mm	150
Stroke length	mm	2000

* Max. output depending on consistency of material to be pumped.

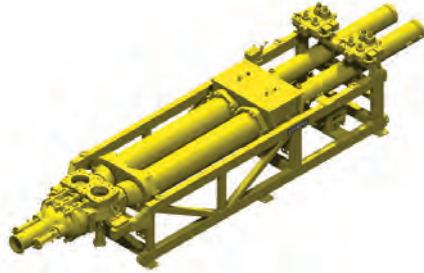
**TECHNICAL DATA**

Min. and max. output*	m ³ /hr	8,0 - 90,0
Max. design pressure	bar	120
Length	mm	6420
Width	mm	1350
Height	mm	1450
Weight approx.	kg	5.700
Diam. of material cylinder	mm	300
Diam. of differential cylinder	mm	200
Stroke length	mm	1600

* Max. output depending on consistency of material to be pumped.

**TECHNICAL DATA**

Min. and max. output*	m ³ /hr	10,0 - 110,0
Max. design pressure	bar	120
Length	mm	7150
Width	mm	1500
Height	mm	1450
Weight approx.	kg	6.300
Diam. of material cylinder	mm	300
Diam. of differential cylinder	mm	200
Stroke length	mm	2000

* Max. output depending on consistency of material to be pumped.

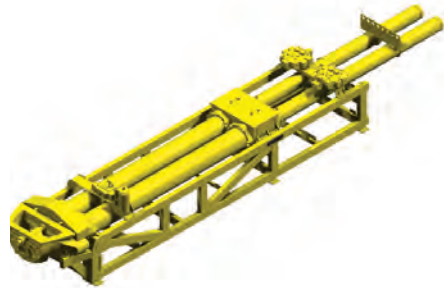
**TECHNICAL DATA**

Min. and max. output*	m ³ /hr	15,0 -150,0
Max. design pressure	bar	100
Length	mm	8810
Width	mm	1500
Height	mm	1450
Weight approx.	kg	5.800
Diam. of material cylinder	mm	300
Diam. of differential cylinder	mm	200
Stroke length	mm	3100

* Max. output depending on consistency of material to be pumped.

**TECHNICAL DATA**

Min. and max. output*	m ³ /hr	20,0 - 220,0
Max. design pressure	bar	110
Length	mm	10000
Width	mm	1700
Height	mm	1700
Weight approx.	kg	10.000
Diam. of material cylinder	mm	360
Diam. of differential cylinder	mm	230
Stroke length	mm	3100

* Max. output depending on consistency of material to be pumped.

MUCK PUMP **TAP 30 R**
TAP 50 R

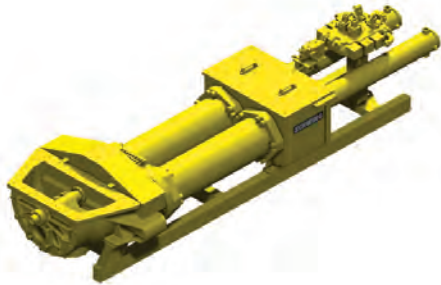

TECHNICAL DATA

TAP 30 R

Min. and max. output*	m ³ /hr	3,0 - 31,0
Max. design pressure	bar	80
Length	mm	3700
Width	mm	950
Height	mm	750
Weight approx.	kg	1.800
Diam. of material cylinder	mm	230
Diam. of differential cylinder	mm	150
Stroke length	mm	700

* Max. output depending on consistency of material to be pumped.

TAP 50 R

Min. and max. output*	m ³ /hr	5,0 - 50,0
Max. design pressure	bar	100
Length	mm	3600
Width	mm	1350
Height	mm	1100
Weight approx.	kg	2.700
Diam. of material cylinder	mm	300
Diam. of differential cylinder	mm	150
Stroke length	mm	500

* Max. output depending on consistency of material to be pumped.

MUCK PUMP **TAP 90 R**
TAP 110 R

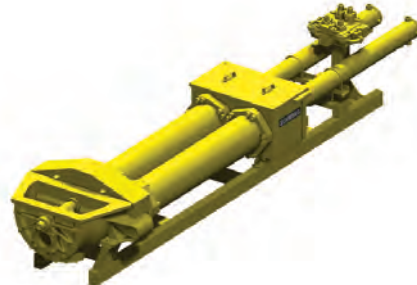

TECHNICAL DATA

TAP 90 R

Min. and max. output*	m ³ /hr	8,0 - 86,0
Max. design pressure	bar	100
Length	mm	4450
Width	mm	1350
Height	mm	1100
Weight approx.	kg	3.300
Diam. of material cylinder	mm	300
Diam. of differential cylinder	mm	150
Stroke length	mm	1000

* Max. output depending on consistency of material to be pumped.

TAP 110 R

Min. and max. output*	m ³ /hr	11,0 - 110,0
Max. design pressure	bar	100
Length	mm	5200
Width	mm	1500
Height	mm	1200
Weight approx.	kg	4.200
Diam. of material cylinder	mm	300
Diam. of differential cylinder	mm	150
Stroke length	mm	1600

* Max. output depending on consistency of material to be pumped.

HYDRAULIC POWER PACKS TO DRIVE SLUDGE PUMP SYSTEMS



TECHNICAL DATA

Model	Power
EHS 100	5,5 kW
	7,5 kW
	11,0 kW
	15,0 kW
EHS 190	15,0 kW
	18,5 kW
	22,0 kW
	30,0 kW
EHS 300	15,0 kW
	22,0 kW
	30,0 kW
	37,0 kW
EHS 400	45,0 kW
	55,0 kW
EHS 630	55,0 kW
	75,0 kW
	90,0 kW
EHS 800	90,0 kW
	110,0 kW
	132,0 kW

* These data apply to electric motors 400 / 690 V – 50 Hz, 1500 rpm.
Models listed above are equipped with an oil tank on top.

HYDRAULIC POWER PACKS TO DRIVE SLUDGE PUMP SYSTEMS

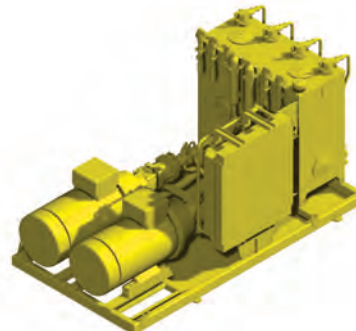

TECHNICAL DATA

Model	Power	Drive capacity of Dual Power Pack
EHS 750	55,0 kW	2 x 22,0 kW
	75,0 kW	2 x 30,0 kW
	90,0 kW	2 x 37,0 kW
	110,0 kW	2 x 45,0 kW
	132,0 kW	2 x 55,0 kW
EHS 1200	90,0 kW	2 x 55,0 kW
	110,0 kW	2 x 75,0 kW
	132,0 kW	2 x 90,0 kW
	160,0 kW	2 x 110,0 kW
EHS 1600	200,0 kW	
	132,0 kW	2 x 90,0 kW
	160,0 kW	2 x 110,0 kW
	200,0 kW	2 x 132,0 kW
EHS 2000	250,0 kW	2 x 160,0 kW
	200,0 kW	2 x 200,0 kW
	315,0 kW	2 x 250,0 kW
		2 x 315,0 kW
EHS 3000	–	2 x 160,0 kW
		2 x 200,0 kW
		2 x 250,0 kW
		2 x 315,0 kW
EHS 4000	–	2 x 250,0 kW
		2 x 315,0 kW
		2 x 355,0 kW
		2 x 400,0 kW
EHS 5000	–	2 x 355,0 kW
		2 x 400,0 kW
		2 x 500,0 kW

* These data apply to electric motors 400 / 690 V – 50 Hz, 1500 rpm.
Models listed above are equipped with an oil tank at side.

SCHWING SYSTEM ENGINEERING PROVIDES:

- all control systems are equipped with programmable logic controllers (PLC)
- switch cabinets in the range from 5,5 kW to 1000 kW according to customers request
- fully automatic control and monitoring of the complete sludge pump system
- full system operation by remote control from customers control centre
- control systems manufactured in accordance with all international standards
- modern automation and visual display systems
- problem-free interface and running system integration

Our service includes consultancy, design, engineering as well as delivery and start-up on site.



TECHNICAL DATA

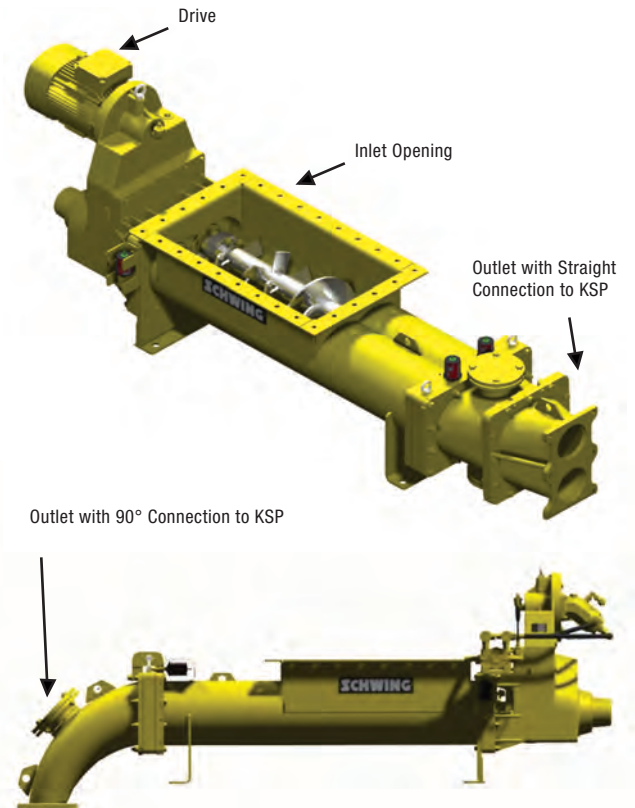

Model	inlet width	inlet length
SD 180	320 mm	variable
SD 250	433 mm	variable
SD 350	600 mm	variable
SD 350 HD	600 mm	variable
SD 425	650 mm	variable
SD 500	883 mm	variable
SD 500 HD	883 mm	variable

DRIVE OF DOUBLE SCREW FEEDER

The Double Screw Feeder is either driven by an electric or a hydraulic motor

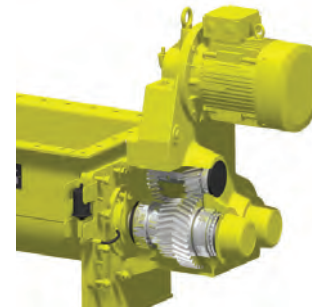

Electric Motor

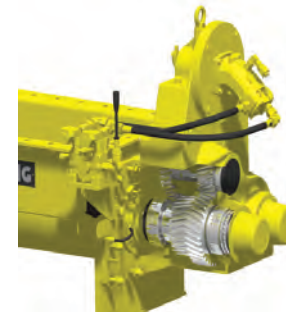

Hydraulic Motor

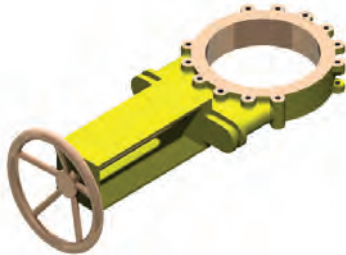
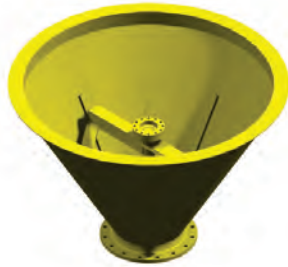

WIDE RANGE OF ACCESSORIES

- shut-off valves / ball valves
- dual outlets
- continuous mixers
- pressure cells
- pressure dampening system
- pressure transmitter (protection against dry running)
- volumetric flow measurement
- soft-push control
- pipeline lubrication system
- coarse particle separator
- hydraulic accumulator
- compensator
- sludge flow measuring system (SFMS)
- pig launching systems
- filling level measuring device
- pulsation dampeners (pressure-vessel)
- agitator hopper
- distribution placing boom
- soundproof hood
- silos with discharging systems
- intermittent valve control systems
- automatic central grease lubrication system
- pipeline distribution system

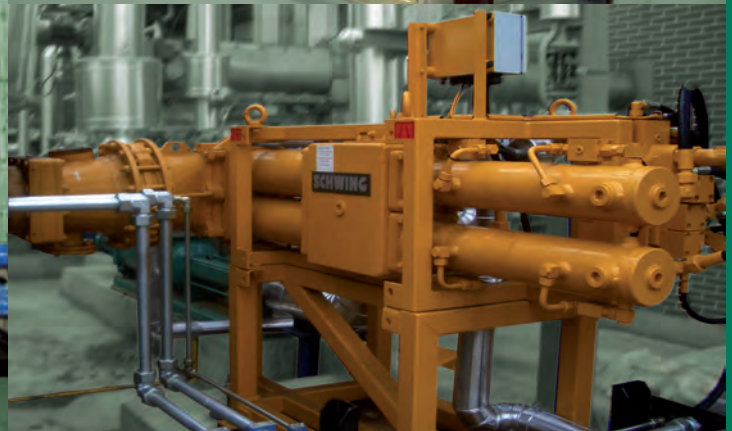
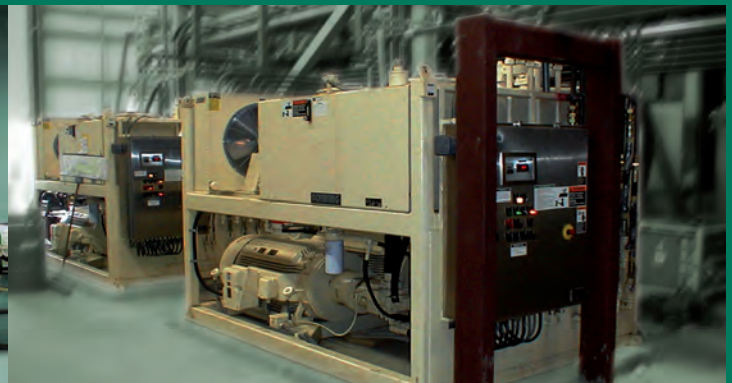



SCHWING GmbH | Heerstraße 9-27 | D - 44653 Herne | T +492325 / 987-0 | F +492325 / 72 922 | info@schwing.de | www.schwing.de