

# FBP 24 / FBP 27

## Truck-mixer pump



**MADE IN GERMANY**  
by SCHWING-Stetter 

Vertical reach		23.80 m / 26.25 m
Concrete output	max.	61 m <sup>3</sup> /h
Pressure on concrete	max.	71 bar
Nominal volume		7 m <sup>3</sup>



RECORD BREAKING ENGINEERING

# The FBP 24 and FBP 27 from SCHWING-Stetter

## Flexible transport and placing

Whether rural or urban: the truck-mixer pumps (FBP) by SCHWING-Stetter are ideal for transporting and placing smaller amounts of concrete and well suited for covering order peaks. Thanks to its small footprint, the FBP offers an optimal solution for construction sites in narrow streets or inner-city areas. The FBP by SCHWING-Stetter: the flexible addition to any fleet.



# The FBP 24 and FBP 27 from SCHWING-Stetter

## Advantages and benefits at a glance

FBP 24 / FBP 27 Truck-mixer pump



### Unique operating comfort

Greater comfort and higher occupational safety: the entire FBP is operated from the ground, except for the cleaning of the mixing drum. All control elements have been combined ergonomically with two central control units. For greater comfort and shorter set-up times.



### Proven boom construction

The RZ-folding boom consists exclusively of straight boom elements without any bends or kinks resulting in a small boom width, low boom weight and higher torsional stiffness. The Z-folding of the final boom section and its large opening angle increases flexibility and enables concrete placing right up to the FBP.

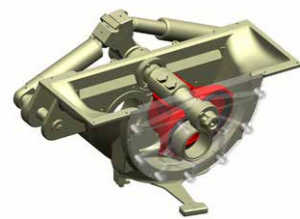

### Low-maintenance and easy cleaning

Specifically designed for truck-mixer pumps: the compact S-ROCK. Its legendary robustness and easy cleaning reduce the maintenance costs and cleaning time to an unmatched low.



### Boom or hose

The rotating outlet (optional) expands the FBP applications. In addition to the classic concrete placing via the boom, the truck-mixer pump will also pump concrete or screed via hose pipes to cover the areas the boom cannot reach. For more flexibility and higher machine utilisation.



### Manoeuvrable and compact

The short rear overhang of the FBP makes manoeuvring at the job site easier and decreases the risk of damage in rough terrain. The small outrigger footprint ensures high set-up flexibility whilst ensuring safe support even on the most restricted construction sites. The large rear outriggers can even be used without pads in many cases.



### All included

Packing more equipment into a truck-mixer pump makes it much more flexible and able to serve a wider variety of situations. Therefore the FBP 24 and FBP 27 provide numerous storage options. Hoses up to 5 m in length can be safely carried along in the aluminium trays mounted on both sides, and in the tool box on the right side is space for couplings, tools and other accessories.

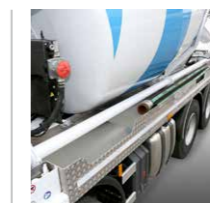

### Easy to service

Daily filling and emptying of the water box can be carried out easily and safely from the ground. Changing the pumping piston can also be done in no time: free access to the water box allows quick work and ensures short downtimes.



## FBP 24 / FBP 27 Truck-mixer pump

# The ROCK

### Faster clean with less water.

Due to its straight design, in comparison to other concrete valves, the ROCK valve is easier and quicker to clean. It also provides a direct view into the delivery cylinder and of the pumping pistons. The pump kit can therefore be cleaned easily and conveniently within just two strokes. This saves water and reduces the time needed for cleaning.

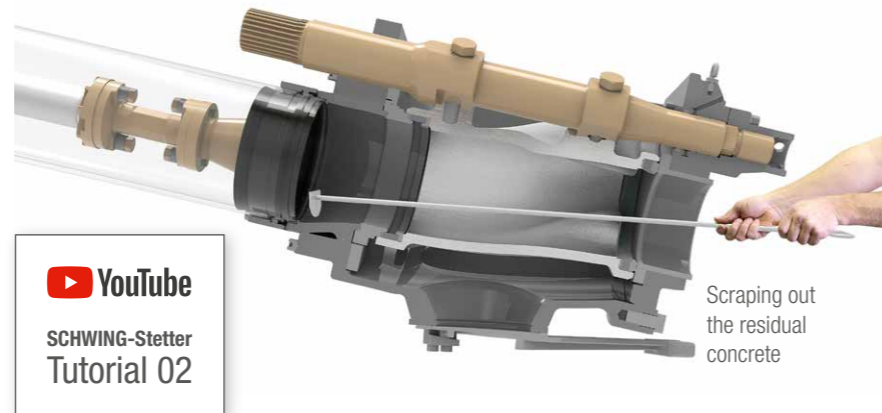

 **YouTube**  
SCHWING-Stetter  
Tutorial 02

### Intelligent wear protection.

The wear in the concrete valve is particularly high as the concrete is fed into the outlet at high pressure. In order to minimize this wear, at the most heavily loaded point of the ROCK concrete does not rub on steel, but rather on concrete. This is because the intelligent design of the ROCK leads to the formation of a concrete triangle after each shift. Protected by this concrete layer, the ROCK has a significantly longer service life than other concrete valves. For noticeably more profit per m<sup>3</sup>.

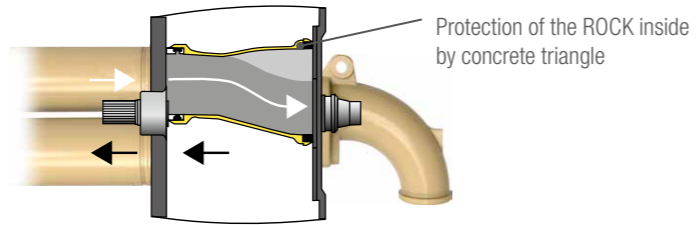
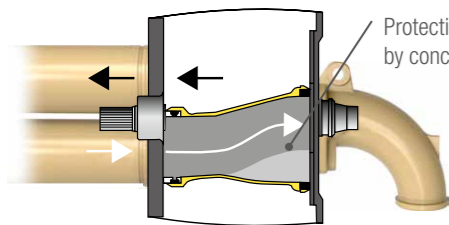

### Easy maintenance.

The ROCK valve not only has a significantly longer service life than other concrete valves, it is also easier to maintain. After removing the housing cover, the wear parts are easily accessible and can be replaced quickly and safely. Time-consuming adjustment work is not required after replacement. And the number of wearing parts at 15 with the ROCK valve is just half as high as with other concrete valves. The maintenance of the ROCK valve: simple, fast and safe.

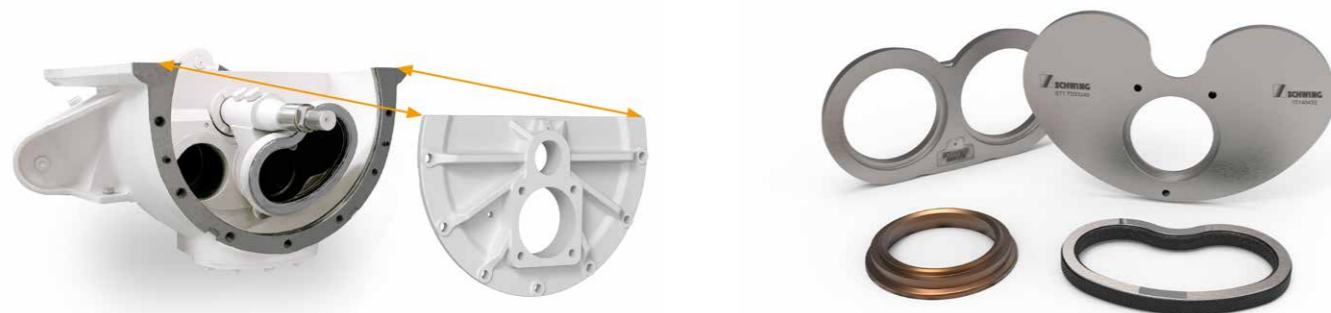

# Working range FBP 24

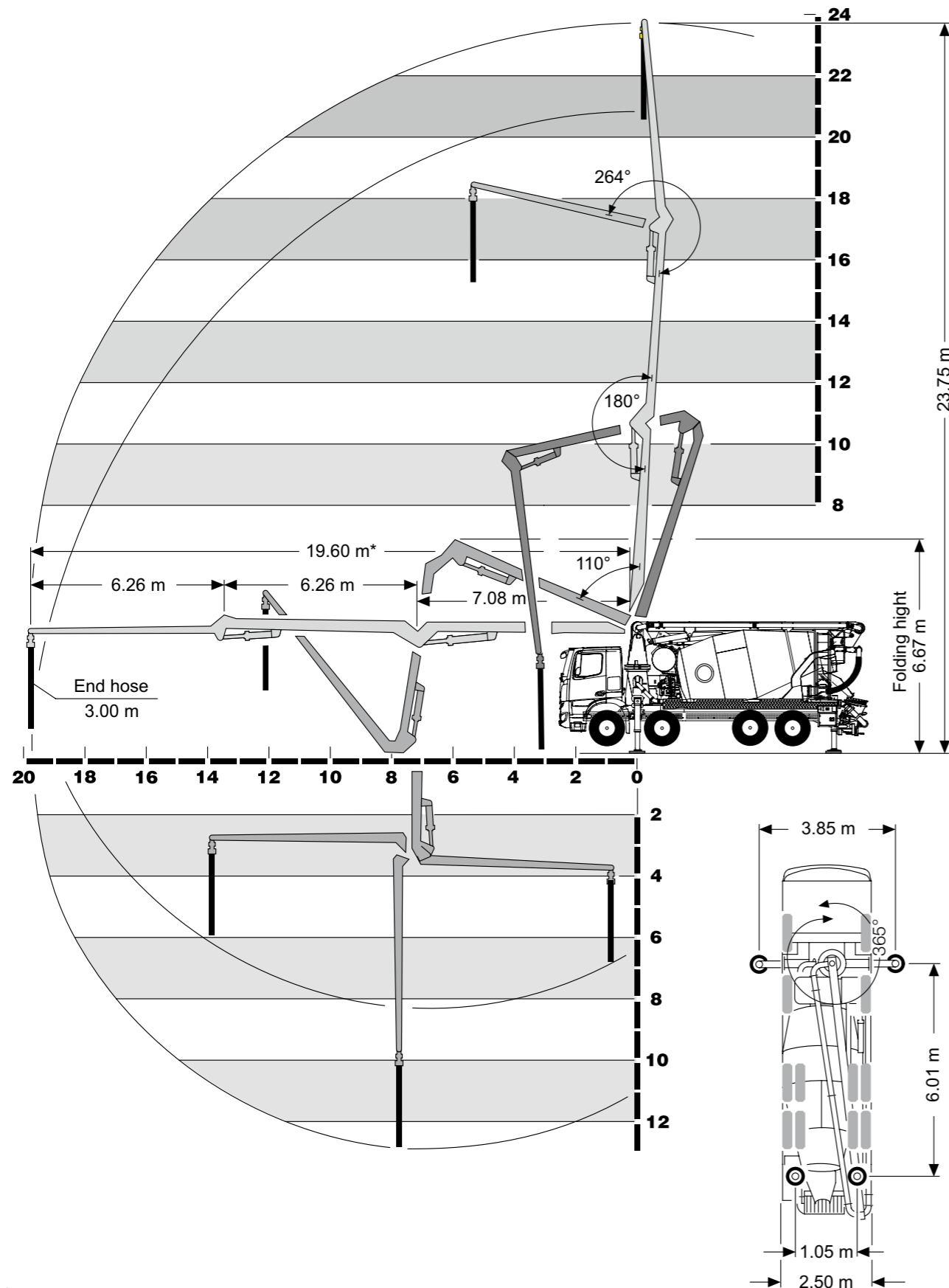

\* from front bumper

# Working range FBP 27

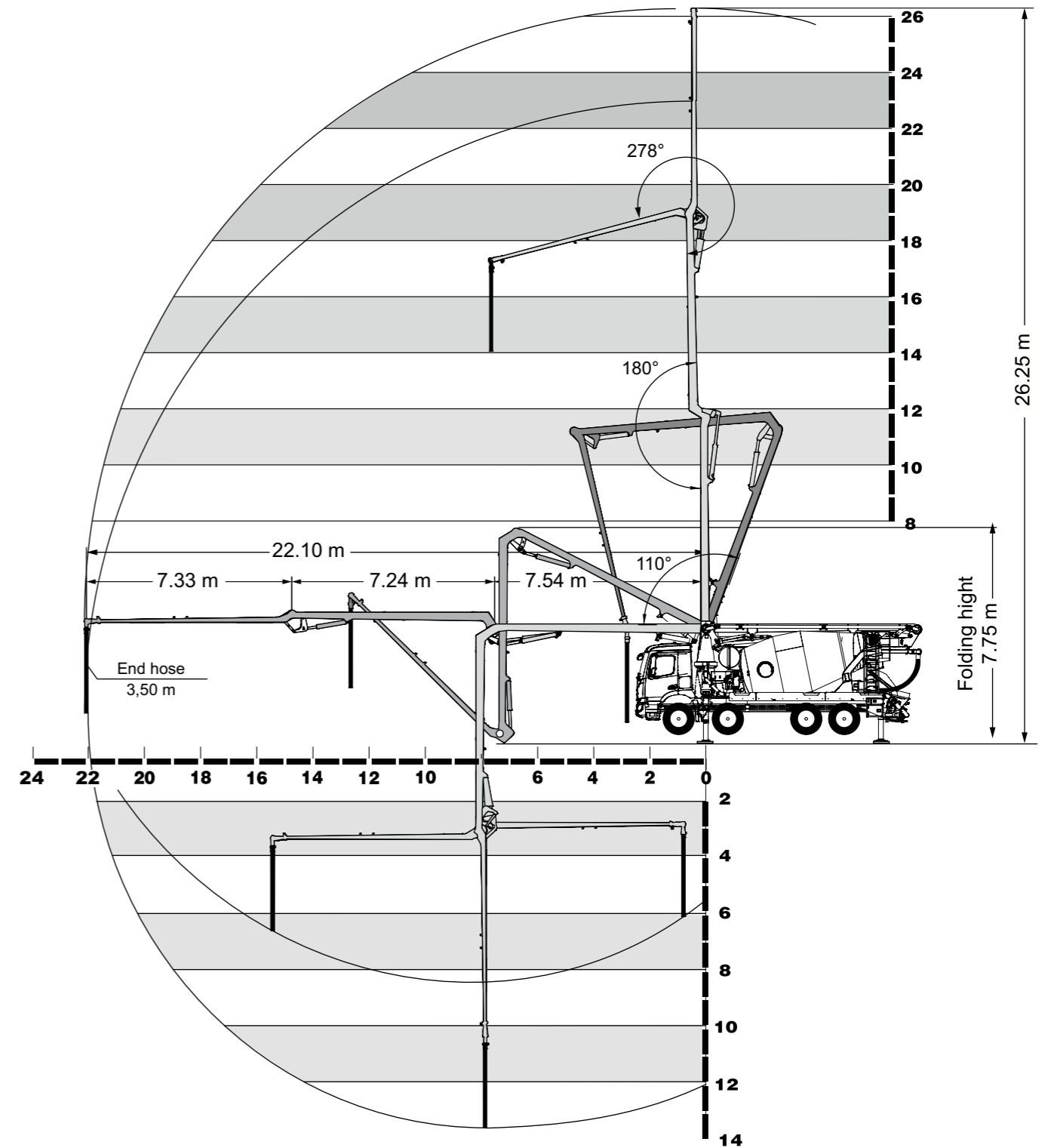

\* from front bumper

# Technical data

Performance		FBP 24	FBP 27	
Pump kit		P1020	P1020	
Delivery cylinders	mm	200 x 1,000	200 x 1,000	
Concrete output max.	m³/h	61	61	
Pressure on concrete max.	bar	71	71	
Stroke rate max.	1/min.	32	32	
Concrete valve		S-ROCK	S-ROCK	
Hydraulic system				
Design		open system		
Hydraulic tank	l	325		
Drum				
Type		AM 7 FHC3 (Light Line)		
Nominal volume	m³	7		
Compressed air water tank	l	650		
Boom		24 Z	27 Z	
Delivery line		DN 125 (Option: DN 100)		
Length of end hose	m	3.00		
Vertical reach	m	23.75		
Reach depth	m	11.64		
Horizontal reach	m	19.60		
Net horizontal reach	m	17.10 (within vehicle width)		
Number of boom sections		3		
Slewing range		365°		
Folding height	m	6.67		
Support				
Outrigger width, front	m	3.85		
Outrigger width, rear	m	1.05 (within vehicle width)		
Outrigger load, front	kN	180		
Outrigger load, rear	kN	125		
Chassis (examples*)		Mercedes-Benz Arocs 3243 B	MAN TGS 35.420 BB	MAN TGS 37.420 BL
Axles configuration		8x4 (2+2)	8x4 (2+2)	8x4 (1+3)
Wheelbase		4,550	4,300	3,300
Length		9,775	9,545	9,995

Maximum concrete output and maximum pressure on concrete cannot be achieved simultaneously.

\*other chassis possible

# Equipment & Options

## Standard equipment

Hydraulic chute adjustment	End hose 3.00 m
Hydraulic chute adjustment	Floodlight on ladder platform
Extension chute (plastic insert exchangeable)	Filling level sensor (switches off the drum when hopper is full)

## Selected options



High pressure cleaner



Rotating outlet (for pumping with hoses)



Concrete shut-off-valve



Oil cooler



Drum cover (3/4 or full lock)



Admixture system (compressed-air version)

## Flexible in use: the covering for hopper



Covering for hopper in position "Own filling"

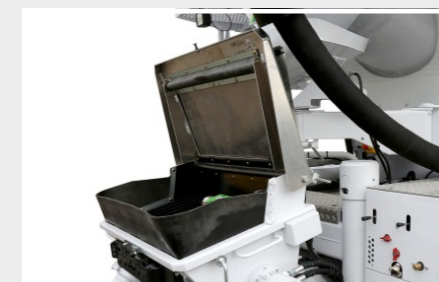

Covering for hopper in position "External filling"



Covering for hopper in position "Own + external filling"



SCHWING-Stetter truck-mixer pumps.  
Flexible transport and placing.



**SCHWING  
Stetter**

SCHWING GmbH  
Heerstrasse 9-27 · 44653 Herne, Germany  
Phone +49 23 25 - 987-0 · Fax +49 23 25 - 72922  
[www.schwing-stetter.com](http://www.schwing-stetter.com) · [info@schwing.de](mailto:info@schwing.de)

Stetter GmbH  
Dr.-Karl-Lenz-Strasse 70 · 87700 Memmingen, Germany  
Phone +49 83 31 - 78-0 · Fax +49 83 31 - 78 275  
[www.schwing-stetter.com](http://www.schwing-stetter.com) · [info@stetter.de](mailto:info@stetter.de)

Subject to technical and dimensional modifications. Illustrations are non-binding. The exact standard specification, the scope of delivery and the technical data are detailed in the offer.