

S 20

Truck-mounted concrete pump



MADE IN GERMANY
 by SCHWING-Stetter 

Vertical reach		19.40 m
Concrete output	max.	111 m ³ /h
Pressure on concrete	max.	108 bar
Operating weight		≤ 18 t



RECORD BREAKING ENGINEERING



The S 20 from SCHWING

The versatile city pump

The smaller the truck-mounted concrete pump, the greater the variety of uses – in the city centre in the morning, in a new suburban area in the afternoon and at a warehouse in the evening. With such diverse uses, the equipment and required accessories of such a city pump are also wide-ranging. At the same time it must be compact and flexible. Just as the S 20 from SCHWING is. Its extremely small space requirement for support, the high load capacity reserve and the high-performance pump battery ensure it can be used for a wide range of applications. The S 20 combines its flexibility with outstanding efficiency – be it when placing concrete with the boom or when using additional pipes or hoses, as is common in this category. The combination of unrivalled low maintenance costs, high reliability and excellent fuel efficiency mean more profit per cubic metre of pumped concrete.

The S 20 from SCHWING

Advantages and benefits at a glance

S 20 Truck-mounted concrete pump

Boom

Short boom elements, large boom opening angles and flexible ZR-fold: with its four-section boom, the S 20 from SCHWING is perfectly equipped for pump applications in warehouses or in confined city centre locations. Thanks to the low unfolding height of only 3.85 m, the S 20 has very good threading properties and can also be set-up in smaller industrial warehouses. The boom can either be fitted with a pipeline DN 125 (standard) or with DN 100 (option).



Pump kit

With the P2023 pump battery, just 20 strokes per minute are required for a concrete output of 98 m³/h. Alternatively, a P2020 pump battery can be installed, which can be operated either on the rod or on the piston side. This enables the S 20 to achieve an output of up to 111 m³ per hour or a pressure on concrete of up to 108 bar. Therefore, even extreme distances can be pumped using additional delivery line.



Dual-circuit hydraulic system

The open SCHWING hydraulic system of the S 20 efficiently transforms the engine power into pumping power with low losses. And thanks to the standard dual-circuit hydraulics with MPS, the ROCK valve can be quickly and forcefully switched even at low stroke rates or with special types of concrete.



Outriggers

The front H-outrigger and the rear vertical outrigger provide the S 20 with its outstanding flexibility. Thanks to its extremely small set-up space, the S 20 can also be set up on construction sites which are inaccessible for other concrete pumps. The optional DN 100 pipeline means that the S 20 only needs to be supported vertically at the front, even when pumping concrete over the boom.



Concrete valve

Thanks to its intelligent design, the ROCK valve suffers significantly less wear and tear than other concrete valves. It is also quick to clean and is demonstrably easier to maintain. The advantages for the S 20: shorter servicing times, higher machine uptime and lower maintenance costs.

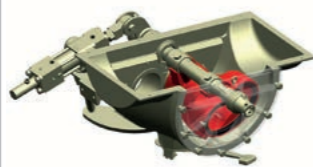

Supply control

The water box can be filled and emptied, and the water pump, agitator, spray hose, high pressure cleaner and compressor, all controlled via the standardised supply control. This is the standard for all SCHWING truck-mounted concrete pumps for greater clarity and ease of operation.



Remote control SC 30

The light weight, easy to use and comfortable SC 30 helps minimise fatigue, allowing the operator to focus on the job for extended periods. The powerful batteries guarantee an operating time of at least 8 hours.



VECTOR control

The machine operator can inspect machine data, operating conditions and settings on S 20, changing various parameters, all through the intuitive VECTOR control. The integrated diagnostic system ensures safe operation and also reminds the operator when maintenance is necessary.



Advantages and benefits in detail

The ROCK

Faster clean with less water.

Due to its straight design, in comparison to other concrete valves, the ROCK valve is easier and quicker to clean. It also provides a direct view into the delivery cylinder and of the pumping pistons. The pump kit can therefore be cleaned easily and conveniently within just two strokes. This saves water and reduces the time needed for cleaning.

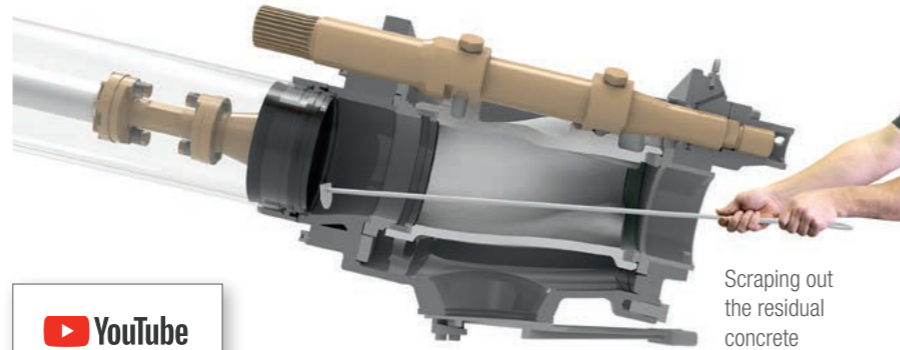

Scraping out the residual concrete



Intelligent wear protection.

The wear in the concrete valve is particularly high as the concrete is fed into the outlet at high pressure. In order to minimize this wear, at the most heavily loaded point of the ROCK concrete does not rub on steel, but rather on concrete. This is because the intelligent design of the ROCK leads to the formation of a concrete triangle after each shift. Protected by this concrete layer, the ROCK has a significantly longer service life than other concrete valves. For noticeably more profit per m³.

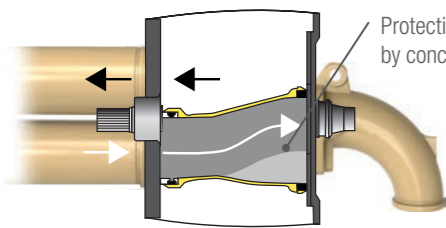

Protection of the ROCK inside by concrete triangle

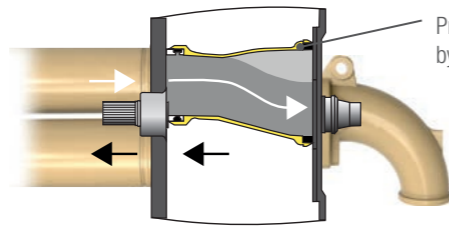

Protection of the ROCK inside by concrete triangle

Easy maintenance.

The ROCK valve not only has a significantly longer service life than other concrete valves, it is also easier to maintain. After removing the housing cover, the wear parts are easily accessible and can be replaced quickly and safely. Time-consuming adjustment work is not required after replacement. And the number of wearing parts at 15 with the ROCK valve is just half as high as with other concrete valves. The maintenance of the ROCK valve: simple, fast and safe.



Pipeline variant DN 100

Reducing support width, expanding the application range.

As standard the boom of the S 20 is fitted with a DN 125 pipeline. An interesting equipment variant is the boom with a DN 100 pipeline, because due to its lower weight this option provides another key advantage: when placing concrete via the boom, the S 20 must only be supported vertically, even at the front. The machine is thus fully supported and is only 2.45 m wide. Which means that it can be used in locations where other concrete pumps cannot be set up in.

Pipeline DN 100

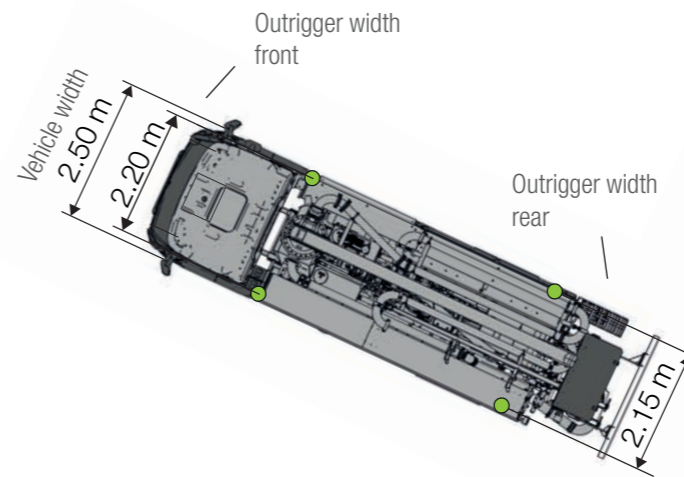

Pipeline DN 125

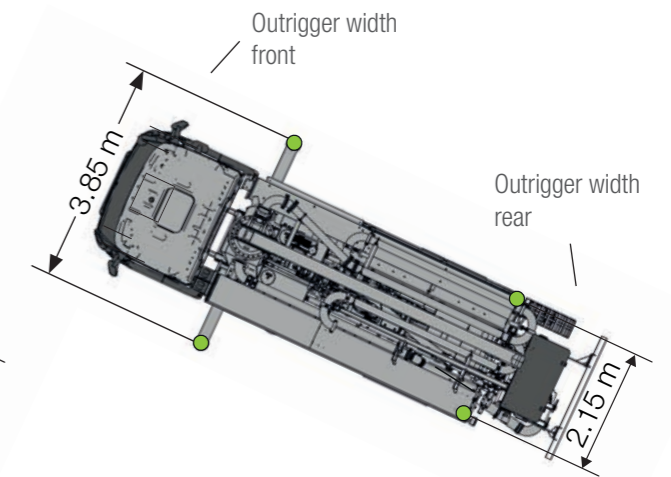

The boom

Master of flexibility

With its ZR-fold, the short boom elements and the large opening angle, the boom of the S 20 is the optimum tool for diverse uses in this machinery class. Through its ease of handling, the low unfolding height of only 3.85 m and the high level of mobility, demanding applications can also be tackled reliably, safely and swiftly.



S 20 Truck-mounted concrete pump

Flexible loadmaster

For the safe transportation and easy handling of the comprehensive equipment, the S 20 can be fitted with a range of different storage options. Thanks to the numerous combination options, each S 20 can be customised to its specific usage profile. Three levels have been defined for a simplified machine configuration. This enables the appropriate equipment to be selected for each level and for each machine side from the range of options available.

S 20 Truck-mounted concrete pump



S 20 on Mercedes-Benz Arocs 1833



S 20 on MAN TGM 18.290

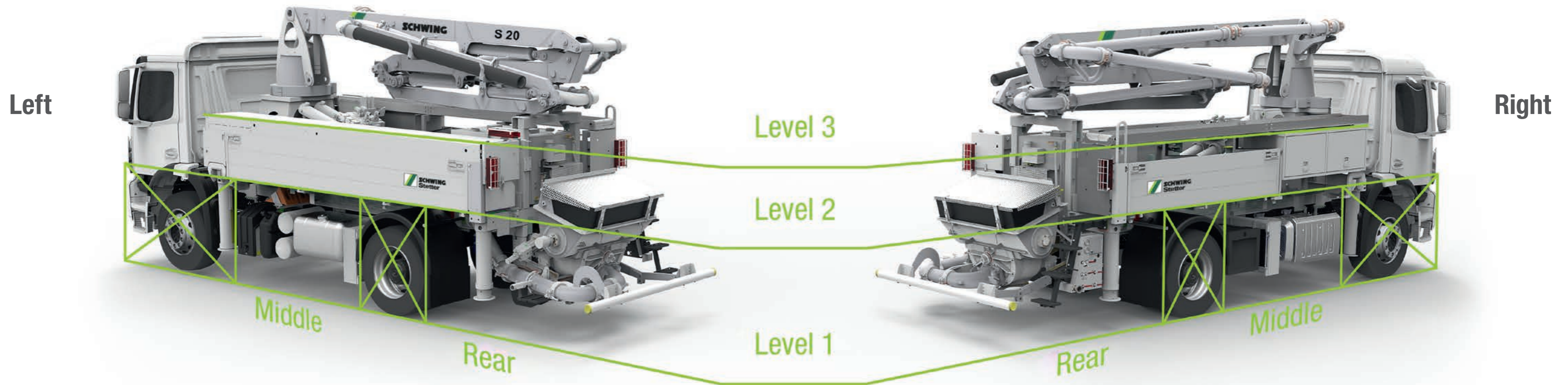

Level 3

Stowing box, 3.10 m detachable	Stowing box, 4.10 m detachable	Stowing box, 4.10 m detachable - with 14 x 125-type sleeves or 8 x 160-type sleeves	Stowing trough, 4.10 m - cannot be combined with detachable stowing boxes - combinable with the railing	Stowing trough, 5.10 m - cannot be combined with detachable stowing boxes - not combinable with the railing
--	--	---	---	--

Level 2

Loading area, 5.00 m with hinged sidewall	Stowing box, 5.00 m - with 20 x 125-type sleeves - or 12 x 160-type sleeves - combinable with the stowing trough at Level 3	Stowing box, 4.00 m - with tool cabinet - with 20 x 125-type sleeves - or 12 x 160-type sleeves
---	--	---

Level 1 (Equipment options of level 1 depending on the chassis)

Central lubrication system, rear	Throw box, rear - with drain holes - for cleaning and transporting of couplings, etc. - hinged	Storage box, rear - 350 mm wide - lockable - not combinable with the storage box at Level 2
--	---	--

Level 3

Stowing box, 3.10 m detachable	Stowing trough, 4.10 m - cannot be combined with detachable stowing boxes - combinable with the railing	Stowing trough, 5.10 m - cannot be combined with detachable stowing boxes - not combinable with the railing
--	---	--

Level 2

Storage box under control cabinet	Loading area, 3.20 m with hinged sidewall	Storage shelf, 1.60 m behind hinged sidewall	Stowing box, 3.00 m - with 20 x 125-type sleeves - or 12 x 160-type sleeves	Tube rack, 3.20 m inc. alu-trough 5.10 m
--	---	--	--	--

Level 1 (Equipment options of level 1 depending on the chassis)

Throw box, rear - with drain holes - for cleaning and transporting of couplings, etc. - hinged	Water hose reel - not combinable with throw box	Storage box, in the middle - 350, 650 or 820 (alternati- vely 2 x 350) mm wide - lockable	Tray on storage box, in the middle - only for storage boxes with 650 and 820 mm width
---	--	--	---

Equipment options

Left

Right

Level 3

Level 3



Stowing box, 3.10 m
detachable



Stowing box, 4.10 m
detachable

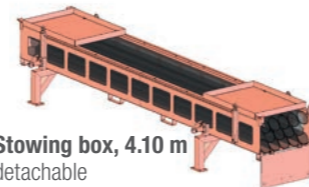

Stowing box, 4.10 m
detachable
with 14 x 125-type sleeves
or 8 x 160-type sleeves



Stowing box, 3.10 m
detachable

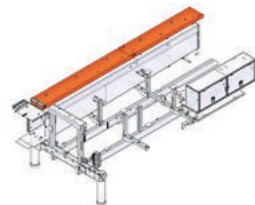

Stowing trough, 4.10 m / 5.10 m
- cannot be combined with detachable stowing boxes
- can be combined with the railing (only with 4.10 m)

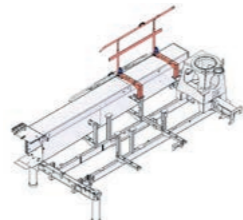

Railing
- not combinable with detachable stowing boxes
- combinable with stowing trough

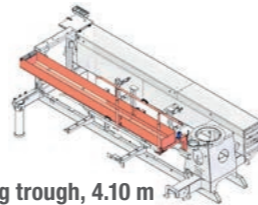

Stowing trough, 4.10 m
combined with the railing

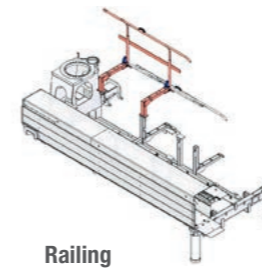

Railing
- not combinable with detachable stowing boxes
- combinable with stowing trough

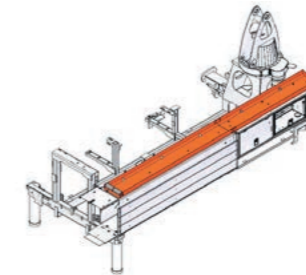

Stowing trough, 4.10 m / 5.10 m
- cannot be combined with detachable stowing boxes
- can be combined with the railing (only with 4.10 m)

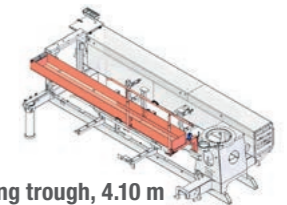

Stowing trough, 4.10 m
combined with the railing

Level 2

Level 2

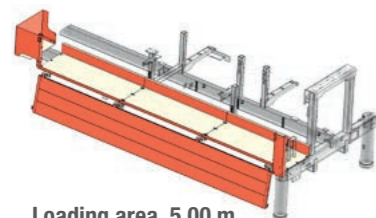

Loading area, 5.00 m
with hinged sidewall

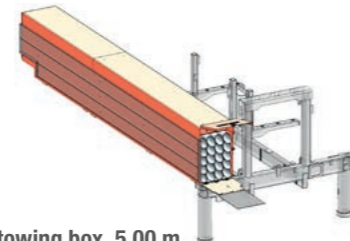

Stowing box, 5.00 m
- with 20 x 125-type sleeves
- or 12 x 160-type sleeves
- can be combined with the stowing trough at Level 3

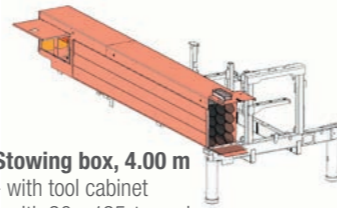

Stowing box, 4.00 m
- with tool cabinet
- with 20 x 125-type sleeves
- or 12 x 160-type sleeves

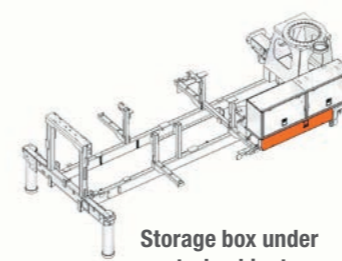

Storage box under control cabinet

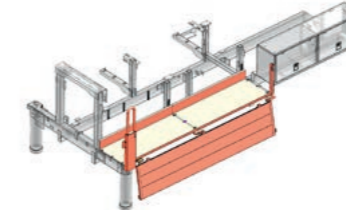

Loading area, 3.20 m
with hinged sidewall

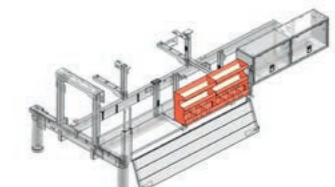

Storage shelf, 1.60 m
behind hinged sidewall

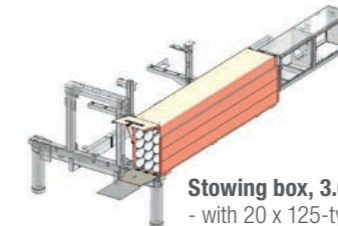

Stowing box, 3.00 m
- with 20 x 125-type sleeves
- or 12 x 160-type sleeves

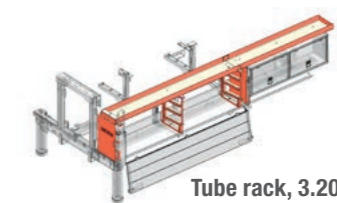

Tube rack, 3.20 m
inc. alu-trough 5.10 m

Level 1

(Equipment options of level 1 depending on the chassis)

Level 1

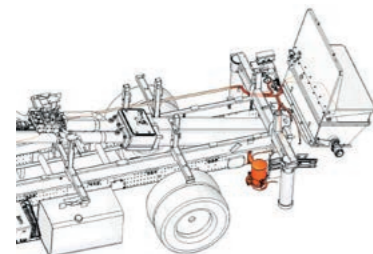

Central lubrication system, rear

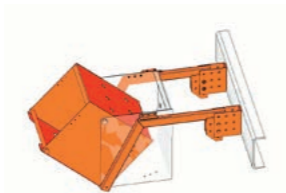

Throw box, rear
- with drain holes
- for cleaning and transporting of couplings, etc.
- hinged

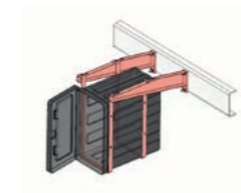

Storage box, rear
- 350 mm wide
- lockable
- can not be combined with the storage box at Level 2

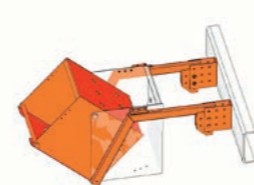

Throw box, rear
- with drain holes
- for cleaning and transporting of couplings, etc.
- hinged

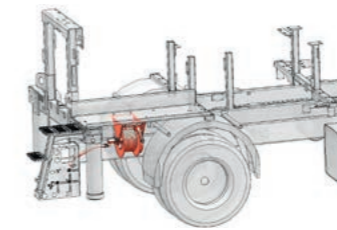

Water hose reel
- not combinable with throw box

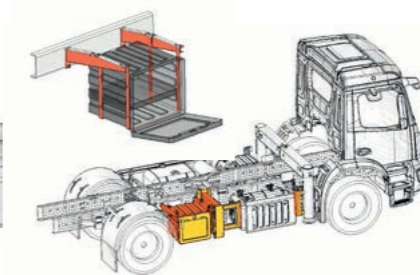

Storage box, in the middle
- 350, 650 or 820 (alternatively 2 x 350) mm wide
- lockable

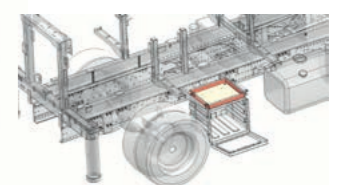

Tray on storage box, in the middle
- only for storage boxes with 650 and 820 mm width

Technical data

Performance		rod-sided	piston-sided
Pump kit		P 2020-120/80	P 2023-110/75
Drive	l/min	380	380
Delivery cylinders	mm	200 x 2,000	230 x 2,000
Concrete output max.	m ³ /h	111	62
Pressure on concrete max.	bar	60	108
Stroke rate max.	1/min.	29	17
Concrete valve		M-ROCK	M-ROCK (Option: B-ROCK)
Hydraulic system			
Design		open system	
Hydraulic tank	l	400	
Boom		20 ZR	
Delivery line		DN 125 (Option: DN 100)	
Length of end hose	m	3.00	
Vertical reach	m	19.40	
Reach depth	m	10.40	
Horizontal reach	m	15.80	
Net horizontal reach	m	13.30* (from front bumper)	
Number of boom sections		4	
Height of the inflexion points	m	3.70 / 8.80 / 12.30 / 15.90	
Slewing range		2 x 365°	
Folding height	m	3.85	
Support			
Outrigger width, front	m	2.20 with DN 100 / 3.85 with DN 125	
Outrigger width, rear	m	2.15	
Outrigger load, front	kN	110	
Outrigger load, rear	kN	70	
Chassis (examples**)			
		Mercedes-Benz Arocs 1833	Mercedes-Benz Arocs 1830
Axles configuration		4x2	4x2
Wheelbase	mm	4,500	4,200
Length	mm	8,700	8,540
		MAN TGM 18.340	
			4x2
Wheelbase	mm		4,125
Length	mm		8,350
Miscellaneous			
Water tank	l	400 (Option: 2 x 400 l)	

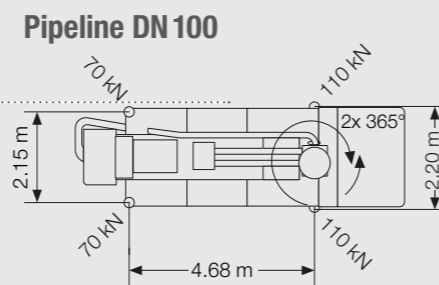
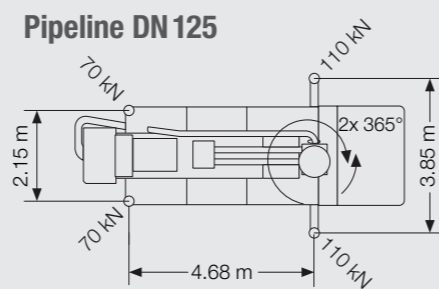

Working range

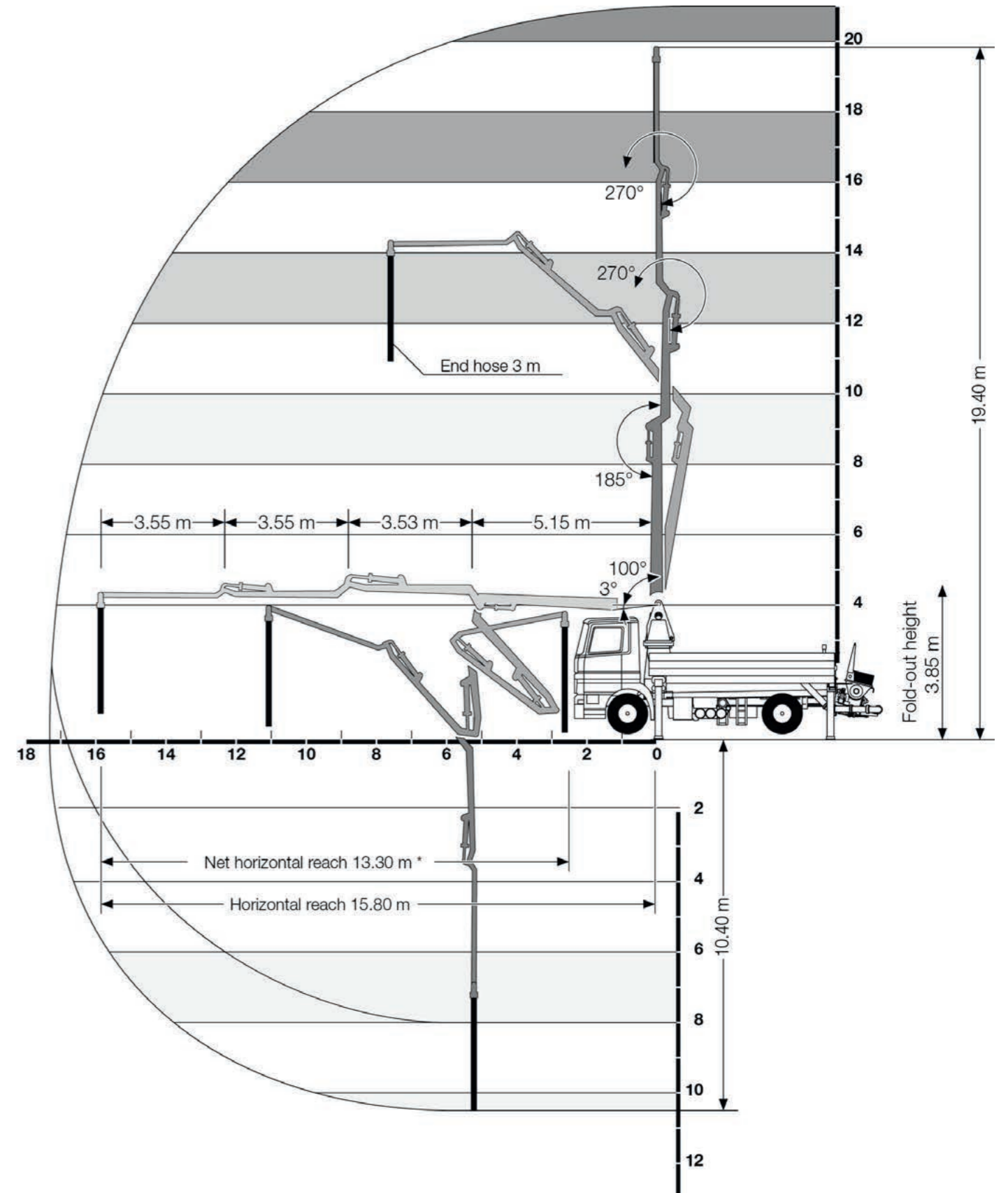

*depending on the chassis **other chassis possible

*from front bumper

S 20 Truck-mounted concrete pump





SCHWING concrete pumps. Efficiency as standard.



SCHWING
Stetter

SCHWING GmbH
Heerstrasse 9-27 · 44653 Herne, Germany
Fon +49 23 25 - 987-0 · Fax +49 23 25 - 72922
www.schwing-stetter.com · info@schwing.de

Stetter GmbH
Dr.-Karl-Lenz-Strasse 70 · 87700 Memmingen, Germany
Fon +49 83 31 - 78-0 · Fax +49 83 31 - 78 275
www.schwing-stetter.com · info@stetter.de

Subject to technical and dimensional modifications. Illustrations are non-binding. The exact standard specification, the scope of delivery and the technical data are detailed in the offer.

10311028.11.2018