

S 65 SXF

Truck-mounted concrete pump



MADE IN GERMANY
by SCHWING-Stetter 

| | | |
|----------------------|------|-----------------------|
| Vertical reach | | 64.25 m |
| Concrete output | max. | 162 m ³ /h |
| Pressure on concrete | max. | 85 bar |



RECORD BREAKING ENGINEERING

An aerial photograph of a large industrial building under construction. The building has a white roof and light-colored walls with a blue and red stripe. Two large concrete pump trucks with long orange booms are positioned on the site, with their booms extended towards the building. The ground is dark and appears to be freshly poured concrete. In the background, there are other buildings and a parking lot. The sky is clear and blue.

The S 65 SXF from SCHWING

Ready for something big

Construction sites with large foundation areas, deep excavations and high engineering structures are the territory of the S 65 SXF. With the standard, long-stroke pump kit P 2525 it reliably pumps up to 162 m³ of concrete per hour and, thanks to its high performance and efficiency, contributes to the success of the project. Components such as the base frame, boom package and outriggers are made of steel from leading Western European manufacturers and produced by SCHWING. The smallest outrigger footprint in the 65 m class plus the boom with overhead roll-folding guarantee easy installation and fast operational readiness. The S 65 SXF made by SCHWING: ready for big tasks.

The S 65 SXF from SCHWING

Advantages and benefits at a glance

S 65 SXF Truck-mounted concrete pump

Boom

The 5-section boom of the S 65 SXF with its continuous DN 125 pipeline and short boom elements 4 (11.15 m) and 5 (10.11 m) provides high efficiency and flexibility during pump operation. With the optional Active boom damping system, possible boom vibrations are almost completely eliminated, thereby further increasing productivity and safety.



Pump kit

The long-stroke pump kit P 2525 fitted as standard has 2.50 m long pumping cylinders. As such, for a customary output of 70 m³ per hour, less than 10 strokes per minute are required. This ensures smooth operation of the S 65 SXF and reduces wear.

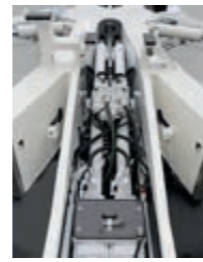

Open hydraulic system

The open hydraulic system of the S 65 SXF with the generously dimensioned components converts the power of the diesel engine into pumping power efficiently and with little loss. Thus, the usual practice output rates can be realized with a fuel-saving engine speed of just over 1000 rpm. This protects the environment and ensures more gain.



SXF outriggers

As the only machine in its class, the S 65 SXF dispenses with multi-telescopic outriggers. This is because the SXF outriggers designed by SCHWING combines the tried-and-tested, single part SX outriggers with a foldable outrigger leg. The benefits vis-à-vis multi-telescopic outriggers are fewer component parts, improved stability and quieter pumping action. Optimum protection from damage is provided by the protected piston rod.

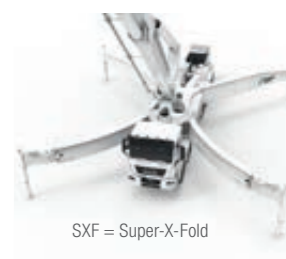

SXF = Super-X-Fold

Concrete valve

Thanks to its intelligent design, the ROCK has a significantly lower level of wear than other concrete valves. It can also be cleaned faster and with less water and is proven to be easier in maintenance. The advantages for the S 65 SXF: shorter stoppage times in the workshop, minimal cleaning times and lower maintenance costs.



Supply control

The water box can be filled and emptied, and the water pump, agitator, spray hose, high pressure cleaner and compressor, all controlled via the standardised supply control. This is the standard for all SCHWING truck-mounted concrete pumps for greater clarity and ease of operation.



Remote control SC 30

The light weight, easy to use and comfortable SC 30 helps minimise fatigue, allowing the operator to focus on the job for extended periods. The powerful batteries guarantee an operating time of at least 8 hours.



VECTOR control

The machine operator can inspect machine data, operating conditions and settings on S 65 SXF, changing various parameters, all through the intuitive VECTOR control. The integrated diagnostic system ensures safe operation and also reminds the operator when maintenance is necessary.



S 65 SXF Truck-mounted concrete pump

Advantages and benefits in detail

The ROCK

Clean faster with less water.

Due to its straight design, in comparison to other concrete valves, the ROCK valve is easier and quicker to clean. It also provides a direct view of the pumping pistons in the delivery cylinder. The pump kit can therefore be cleaned easily and conveniently within just two strokes. This saves water and reduces the time needed for cleaning.

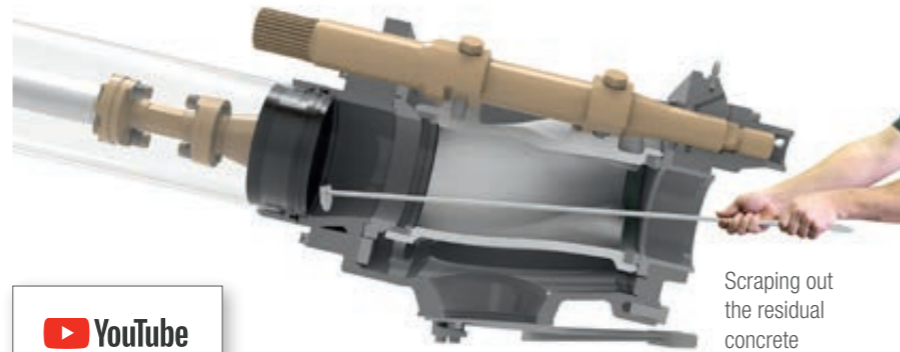

Intelligent wear protection.

The wear in the concrete valve is particularly high as the concrete is fed into the outlet at high pressure. In order to minimize this wear, at the most heavily loaded point of the ROCK concrete does not rub on steel, but rather on concrete. This is because the intelligent design of the ROCK leads to the formation of a concrete triangle after each shift. Protected by this concrete layer, the ROCK has a significantly longer service life than other concrete valves. For noticeably more profit per m³.

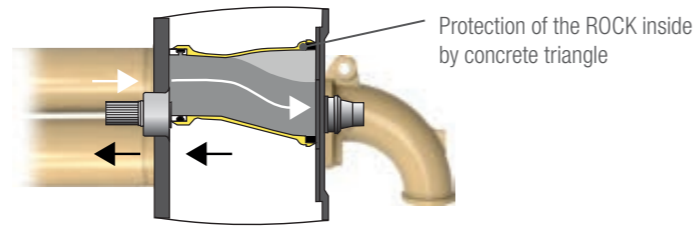
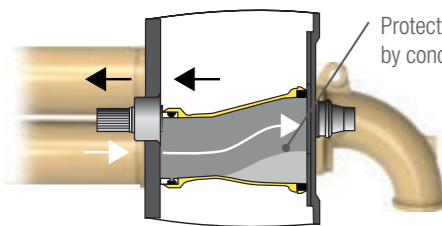

Easy maintenance.

The ROCK valve not only has a significantly longer service life than other concrete valves, it is also easier to maintain. After removing the housing cover, the wear parts are easily accessible and can be replaced quickly and safely. Time-consuming adjustment work is not required after replacement. The ROCK valve's 15 wearing parts is only half the number used in other concrete valves. The maintenance of the ROCK valve: simple, fast and safe.

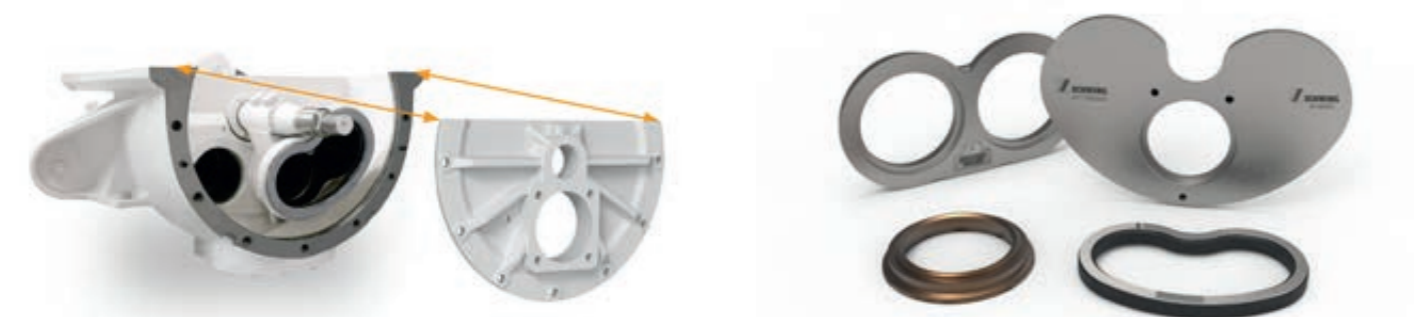

The boom

Quick into position. Optimal usage of the boom length.

Due to the easy-to-operate overhead roll folding, the boom of the S 65 SXF with the continuous DN 125 delivery line can be folded out forwards, directly over the driver's cab without time-consuming turning. This significantly reduces set-up time, especially when working over the driver's cab. Thanks to the long boom elements 2 and 3, the pivot point to the boom element 4 can be positioned high up and thus ideally to the edge of the building. In combination with the short boom elements 4 (11.15 m) and 5 (10.11 m) the boom length of the S 65 SXF can be optimally used especially on high buildings. These also make it easier to reach the desired end hose position in difficult job site situations. The optional boom damping system Active almost completely eliminates possible boom vibrations and therefore increases productivity and safety in the pump operation.

Overhead roll folding



This enables direct unfolding over the driver's cab in the direction of the working area: the overhead roll folding.

Short boom elements 4 and 5



Due to the short length of the last two boom elements 4 and 5, the S 65 SXF's long range can be optimally utilised.

Low fold-out height



Less is more: the low unfolding height expands the S 65 SXF area of application and eases the folding out at tight jobsites.

Boom element 1 with 170° opening angle

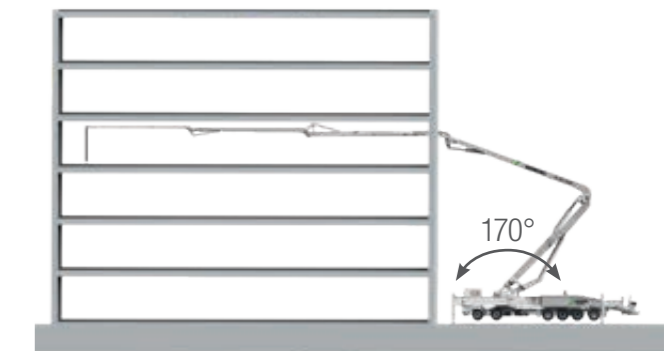

The 170° opening angle of the first boom element provides the S 65 SXF with exceptionally good threading properties and allows deep immersion in building openings.

EASy and EASyflex

EASy
EASyflex

S 65 SXF Truck-mounted concrete pump

The outrigger systems EASy and EASyflex extend the range of applications of the S 36 X DirectDrive. With EASy, the concrete pump can be safely supported on one side, if required. Thereby covering a working range of 133°. EASyflex provides further outrigger combinations and as such, more flexibility on the jobsite. In this way, pump applications can be achieved with the maximum working safety even in difficult, restricted spaces. More flexibility for more safety.

EASy

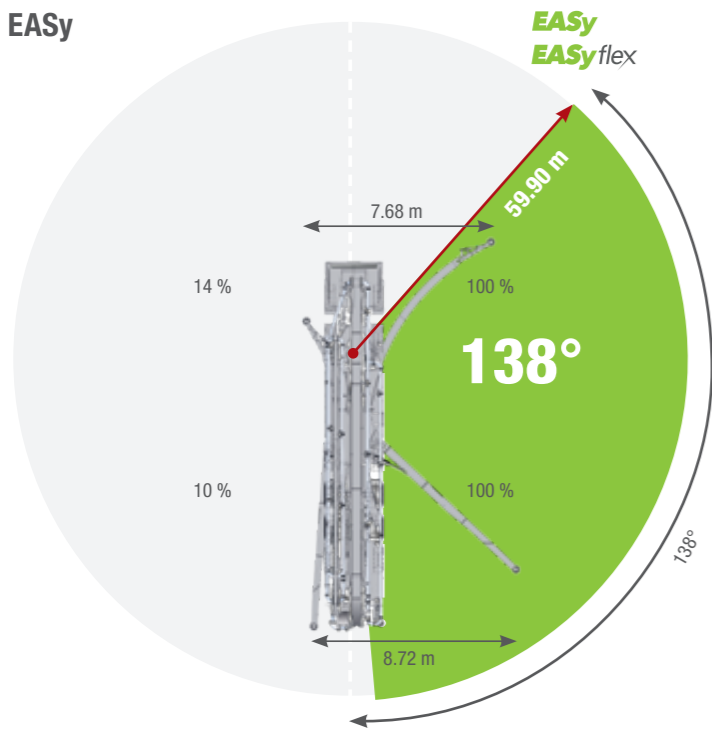

EASyExtend

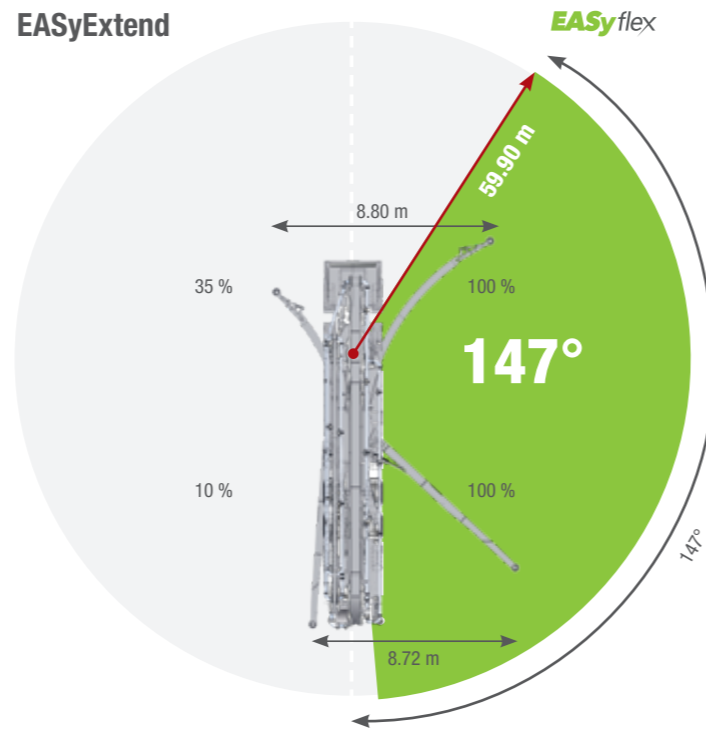

EASyFront

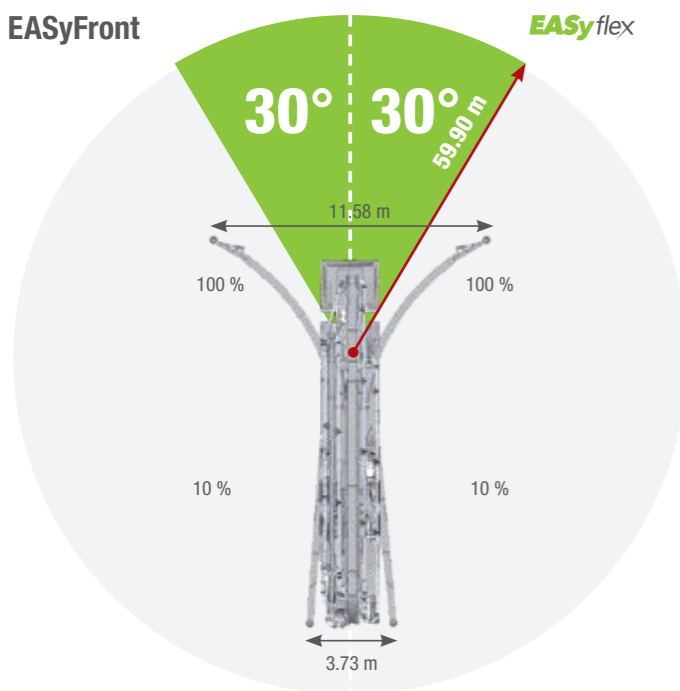

EASy with EASyFront

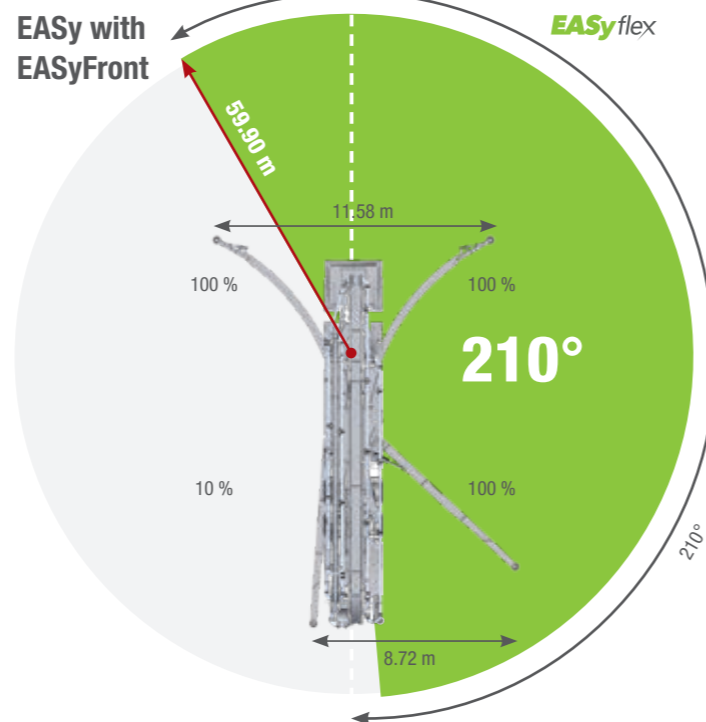

Permissible work area
Angles are based on the vehicle longitudinal axis

The outrigger spreads as specified are measured from the centre of the outrigger leg. Any cribbing or underlay timbers must be taken into account when determining the required set-up area.

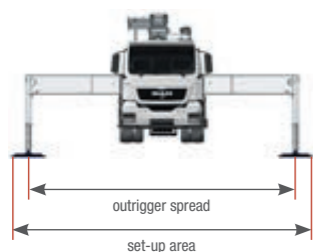

Working range

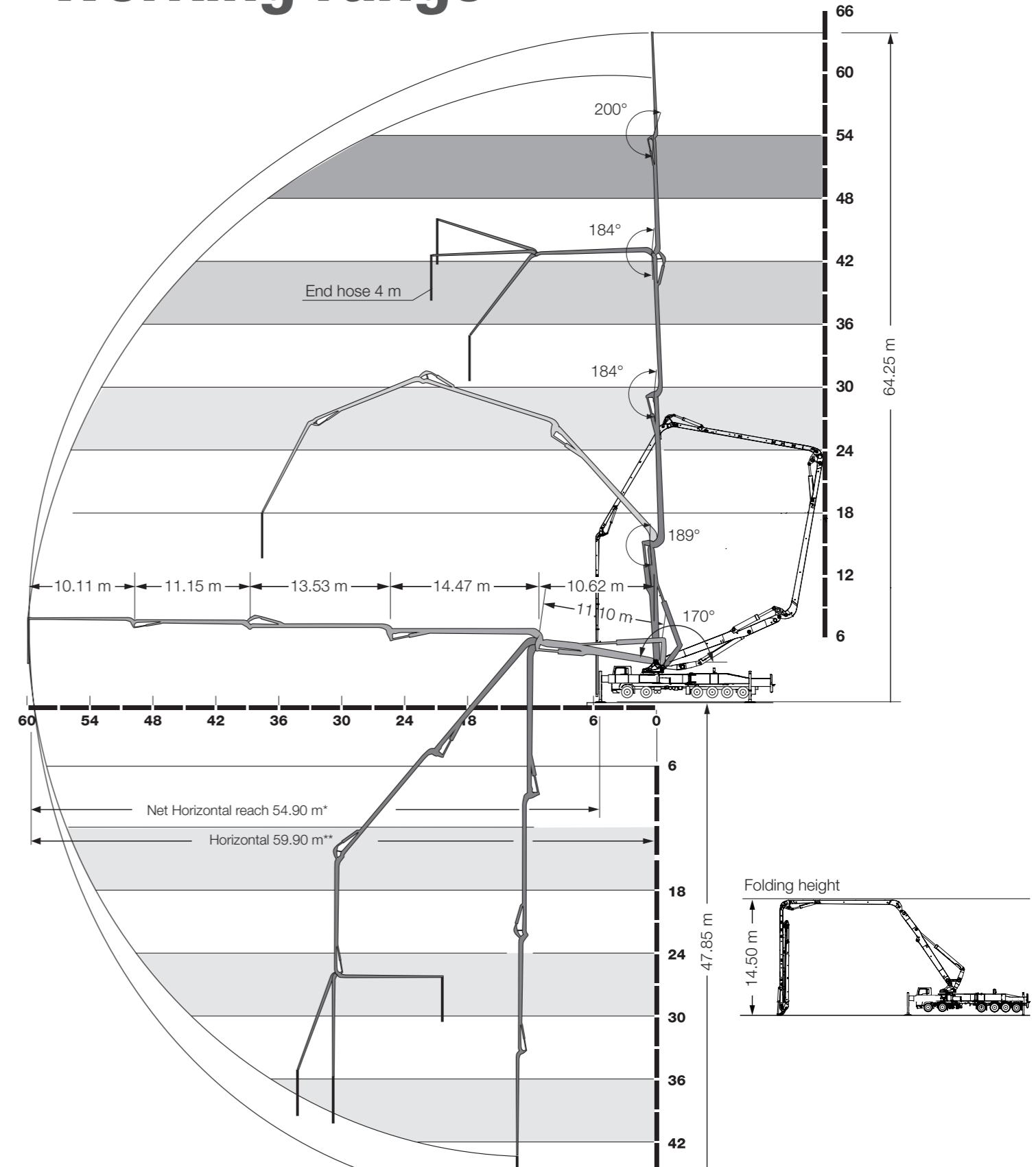

*from front of outriggers
**from centre of turret

S 65 SXF Truck-mounted concrete pump

Technical data

| Performance | | |
|------------------------------|-------------------|--|
| Pump kit | P2525-120/85 | |
| Drive | l/min | 636 |
| Delivery cylinders | mm | 250 x 2,500 |
| Concrete output max. | m ³ /h | 162 |
| Pressure on concrete max. | bar | 85 |
| Stroke rate max. | 1/min. | 22 |
| Concrete valve | B-ROCK | |
| Hydraulic system | | |
| Design | open system | |
| Hydraulic tank | l | 650 |
| Boom | | |
| | 65 R | |
| Delivery line | DN 125 | |
| Length of end hose | m | 4.00 (Option: 1.00 m + 3.00 m) |
| Vertical reach | m | 64.25 |
| Reach depth | m | 47.85 |
| Horizontal reach | m | 59.90 (from centre of turret) |
| Net horizontal reach | m | 54.90 (from front of outriggers) |
| Number of boom sections | 5 | |
| Height of joints (supported) | m | 3.80 / 14.90 / 29.40 / 43.00 / 54.10 |
| Slewing range | 2 x 185° | |
| Folding height | m | 14.50 |
| Support | | |
| Outrigger width, front | m | 11.58 |
| Outrigger width, rear | m | 13.70 |
| Outrigger load, front | kN | 470 |
| Outrigger load, rear | kN | 410 |
| Chassis (examples*) | | |
| | MAN TGS 65.500 | Mercedes-Benz Arocs 6553 |
| Axles configuration | 12x4 (2+4) | 12x4 (3+3) |
| Wheelbase | 6,700 | 8,400 |
| Length | 15,930 / 15,660 | 15,932 / 15,670 (with / without underride guard) |
| Miscellaneous | | |
| Water tank | l | 610 |

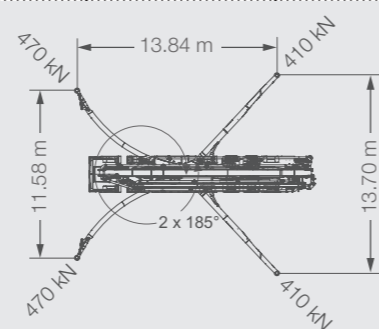



Film



Brochure



SCHWING concrete pumps. Efficiency as standard.



SCHWING
Stetter

SCHWING GmbH
Heerstrasse 9-27 · 44653 Herne, Germany
Phone +49 23 25 - 987-0 · Fax +49 23 25 - 72922
www.schwing-stetter.com · info@schwing.de

Stetter GmbH
Dr.-Karl-Lenz-Strasse 70 · 87700 Memmingen, Germany
Phone +49 83 31 - 78-0 · Fax +49 83 31 - 78 275
www.schwing-stetter.com · info@stetter.de

Subject to technical and dimensional modifications. Illustrations are non-binding. The exact standard specification, the scope of delivery and the technical data are detailed in the offer.