



SP 7500 D

Stationary concrete pump

Technical data

Designation		SP 7500 D Stage IV/Tier 4f			
Weight	kg	9,400		max. single outrigger load	kN/kg/lb 41 / 4,180
Length	mm	7,050			
Height	mm	2,700			
Width	mm	2,180			
Performance		rod-sided	piston-sided		
Pump kit		P2018			
Delivery cylinders	mm	180 x 2,000			
Concrete output max.	m ³ /h	67	44		
Pressure on concrete max.	bar	156	243		
Stroke rate max.	1/min.	22	14		
Concrete valve		HP-ROCK		wear parts both sides	carbide/chrome
Hopper capacity	l	600		outlet diameter	DN 150
Hydraulic system					
Design		open system, dual-circuit hydraulics			
Hydraulic tank	l	700			
Motor					
Motor		Diesel engine CAT C9			
Engine power	kW	298		max. rpm	1/min 2,200
Emission standard		Stage IV/Tier 4f		max. sound level	dB(A) <123
Emission control system		DPF + SCR			
Fuel tank	l	400			
Equipment					
Standard equipment		<ul style="list-style-type: none"> High-pressure pump kit P2018 Dual-circuit hydraulic system Double pressure accumulator Hydrostatically driven fan Fuel tank with double-sided tank nozzles 	<ul style="list-style-type: none"> Cable remote control with 30 m cable Four lashing eyes at the bottom Four attachment points at the top Central greasing strip at the hopper Emergency-off button at the hopper and water box 	<ul style="list-style-type: none"> Batteries 2 x 12 V, each with 143 Ah (on-board voltage: 24 V) Supporting leg, two-stage Pressure gauge for hydraulic pressure and for accumulated charge pressure Carbide wearing parts 	
Options		<ul style="list-style-type: none"> Water pump Hydraulic outriggers Concrete vibrator on the grid Central lubrication system 	<ul style="list-style-type: none"> Hydraulic control unit (f. e. for driving a shut-off valve) SmartSwitch 	<ul style="list-style-type: none"> Various outlet options Compressor Floodlight 	

Maximum concrete output and maximum pressure on concrete cannot be achieved simultaneously.
 DPF: Diesel particulate filter; SCR: selective catalytic reduction



SCHWING
Stetter

SCHWING GmbH
 Heerstrasse 9-27 · 44653 Herne, Germany
 Fon +49 23 25 - 987-0 · Fax +49 23 25 - 72922
 www.schwing-stetter.com · info@schwing.de

Stetter GmbH
 Dr.-Karl-Lenz-Strasse 70 · 87700 Memmingen, Germany
 Fon +49 83 31 - 78-0 · Fax +49 83 31 - 78 275
 www.schwing-stetter.com · info@stetter.de



SP 7500 D

Stationary concrete pump

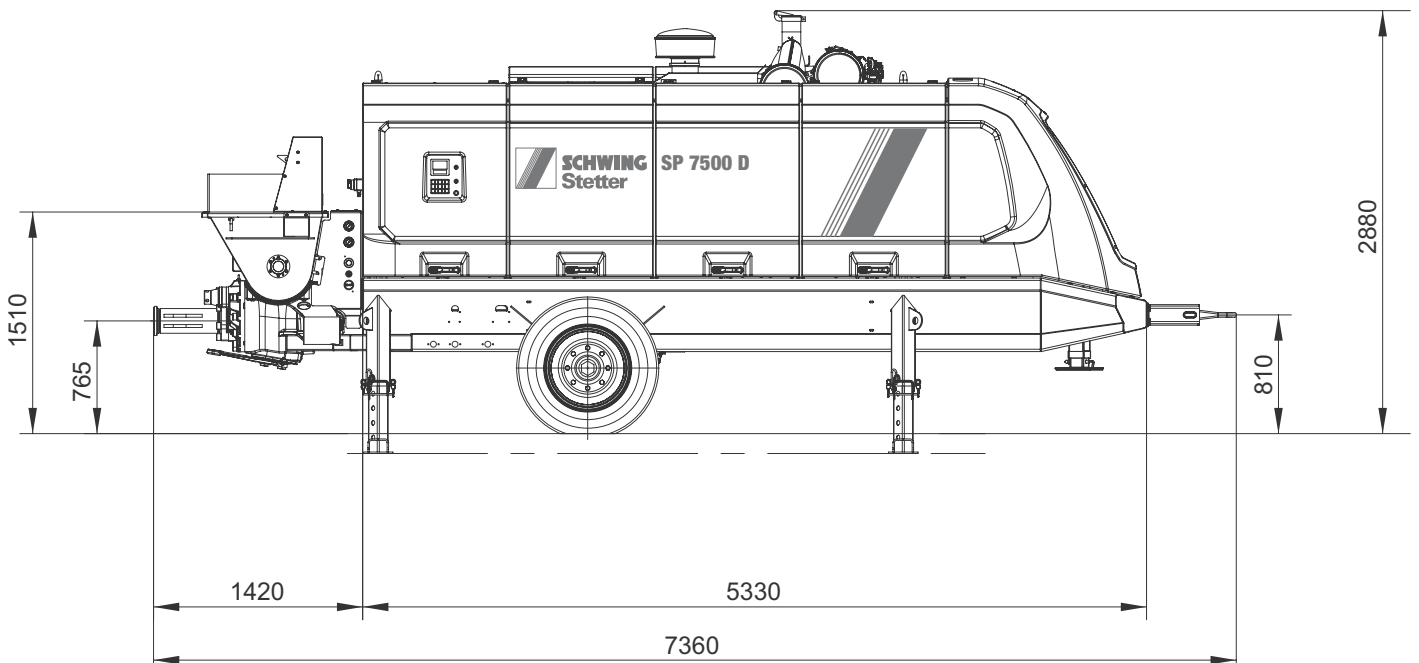
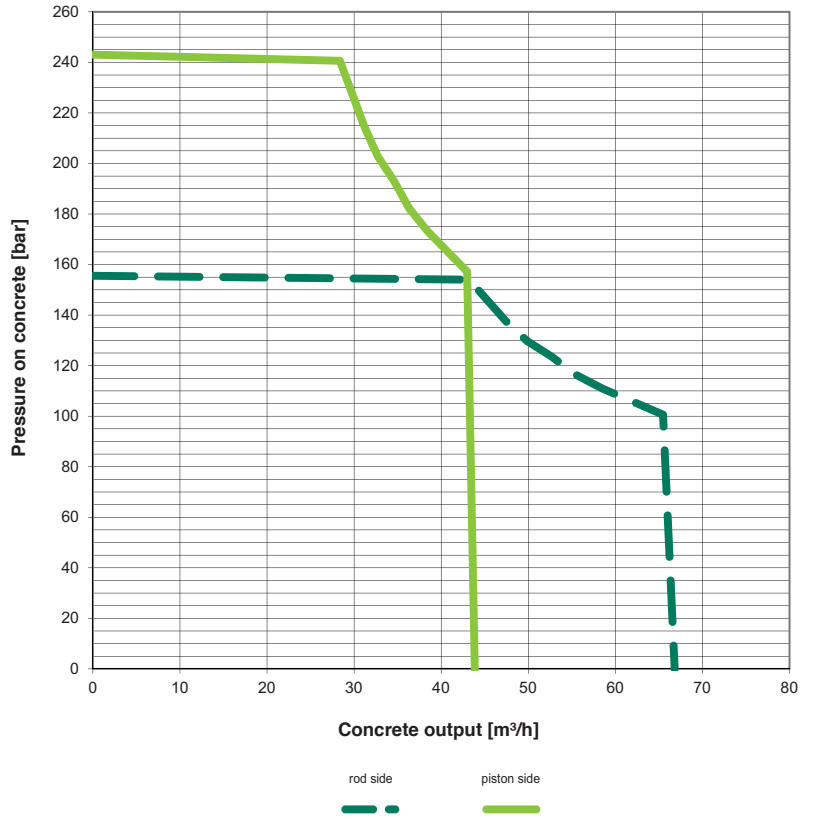
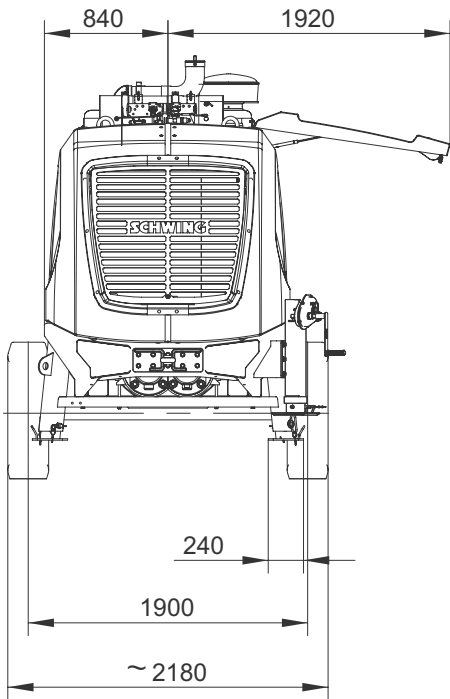

RECORD BREAKING ENGINEERING